

Phone booth M,
by Kettal Studio

kettal

Description

Designer
Kettal Studio

Collection
Phone Booth

Privacy can be hard to come by in large open offices. Our Phone booth O allows your employees to make calls or hold video conferences with unbroken focus and without disturbing the rest of the team. The Phone booth O design is inspired by the traditional telephone booth. They are an elegant yet functional solution for your office. Comfortable and echo-free, the Phone booth O is also simple to install.

	Height	Width	Length
S	240 / 94,5"	117 / 46	117 / 46
L	240 / 94,5"	217 / 85,4"	117 / 46
XL	240 / 94,5"	217 / 85,4"	217 / 85,4"

Bespoke sizes on demand



Isometric view

Designer
Kettal Studio

Collection
Phone Booth

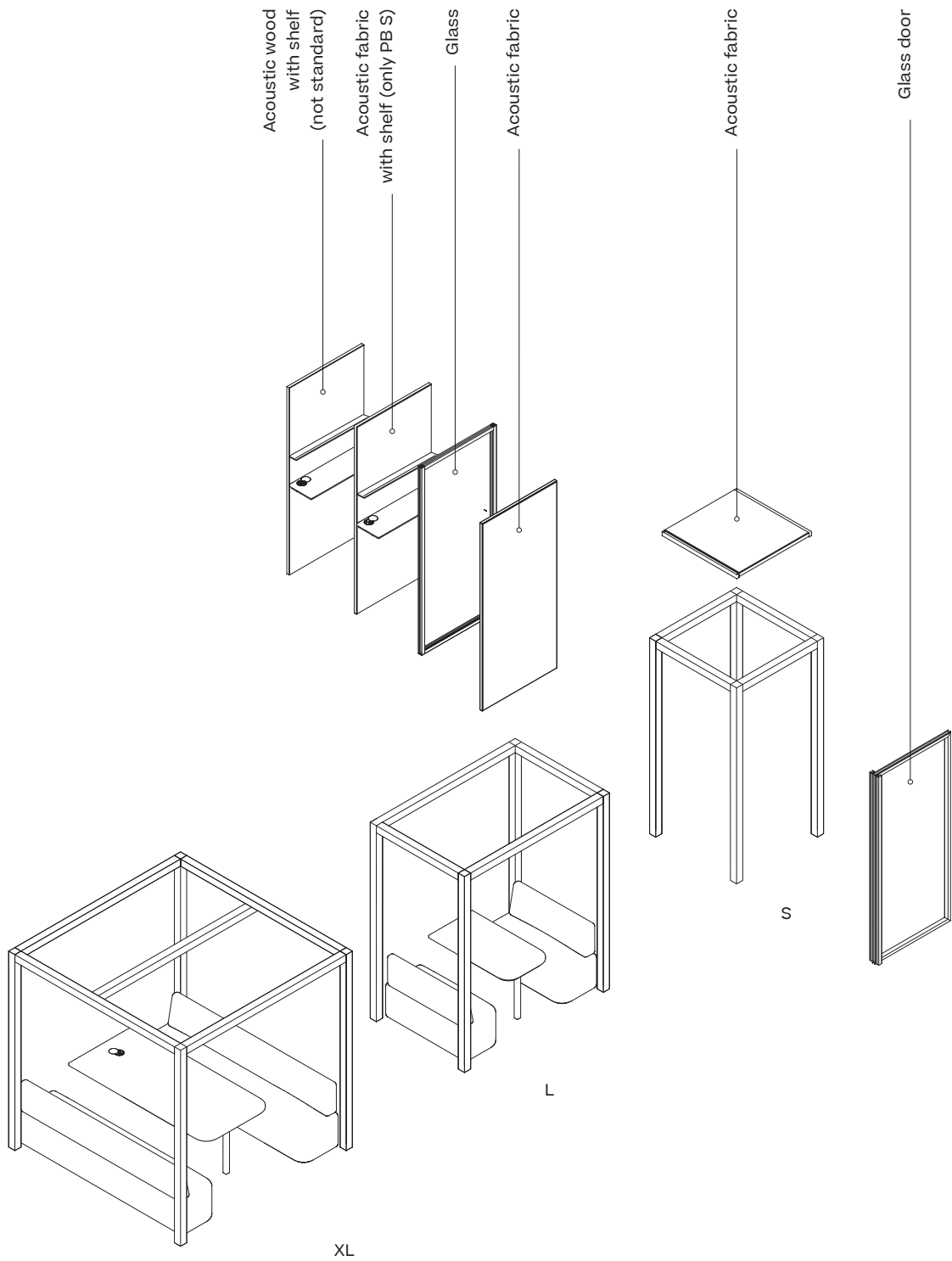

Features

Designer
Kettal Studio

Collection
Phone Booth



Table with Plug / USB- A / USB-C



High or low table with Lamp / Plug / USB-A / USB-C (**)



Shelf + Led light + PIR (*)

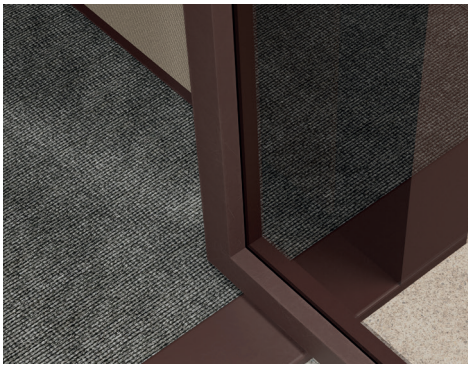

Handicap flooring, pivoting door



LED track curtain

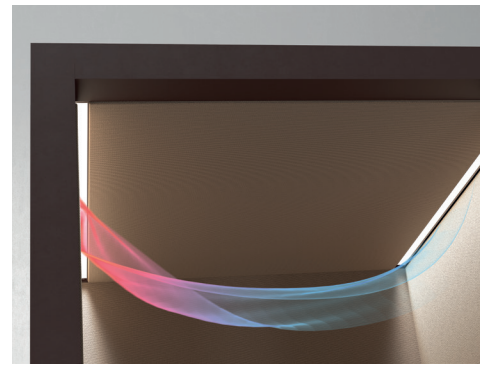

Ventilation system 37,4 m³/h



Motion sensor PIR



Plug and play

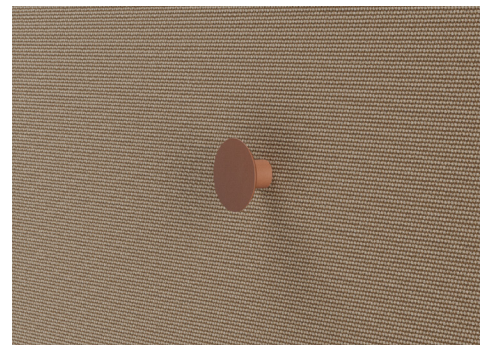

Hanger (*)

Phone booth S

Designer
Kettal Studio

Collection
Phone Booth

Description

A phone booth with one seat. Ideal to join a call or video conference with your client, free from all distractions. The exceptional acoustics and physical comfort allow for better communication, as well as concentration.

Specifications

- Single or double glazed wall system
- Pivot door
- Metal frame
- Acoustic panels
- Absorption system
- Fabric or glass
- Faced external wall
- Air ventilation system
- LED lighting
- PIR sensor



Phone booth S

Designer
Kettal Studio

Collection
Phone Booth

Version A



3 fabric sides + glass door

Version B



2 fabric sides & 1 glass side + glass door

Does not include bar stool.

Phone booth S

Designer
Kettal Studio

Collection
Phone Booth

Detailed dimensions

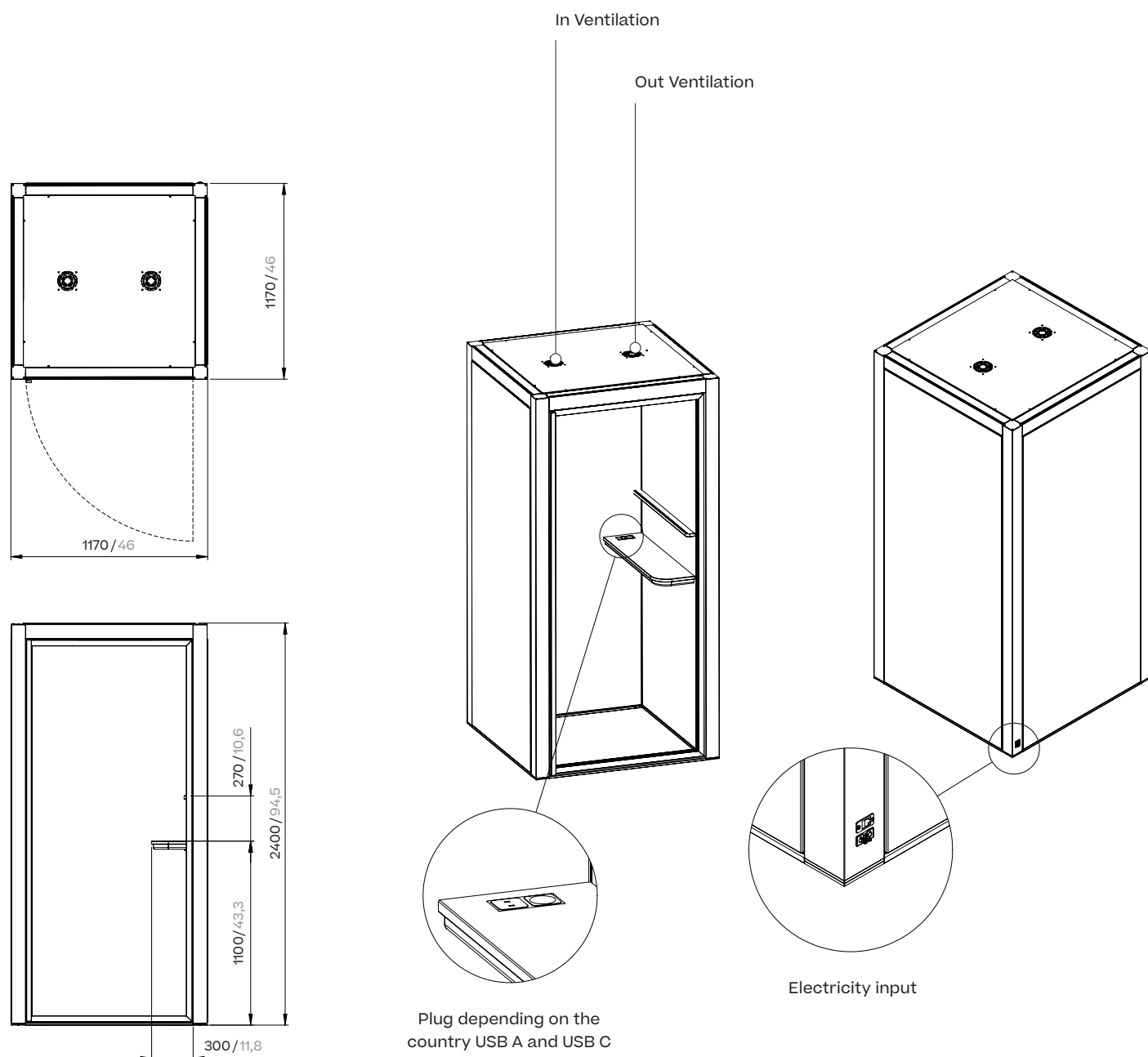

Phone booth S

Designer
Kettal Studio

Collection
Phone Booth

S Phone Booth Light



Phone booth S

Designer
Kettal Studio

Collection
Phone Booth

S Phone Booth Light

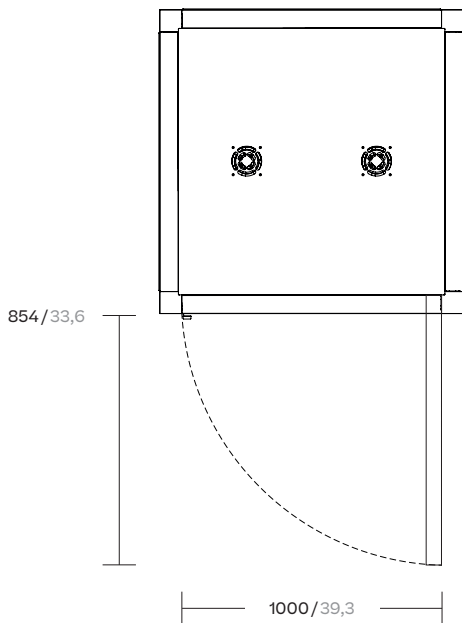
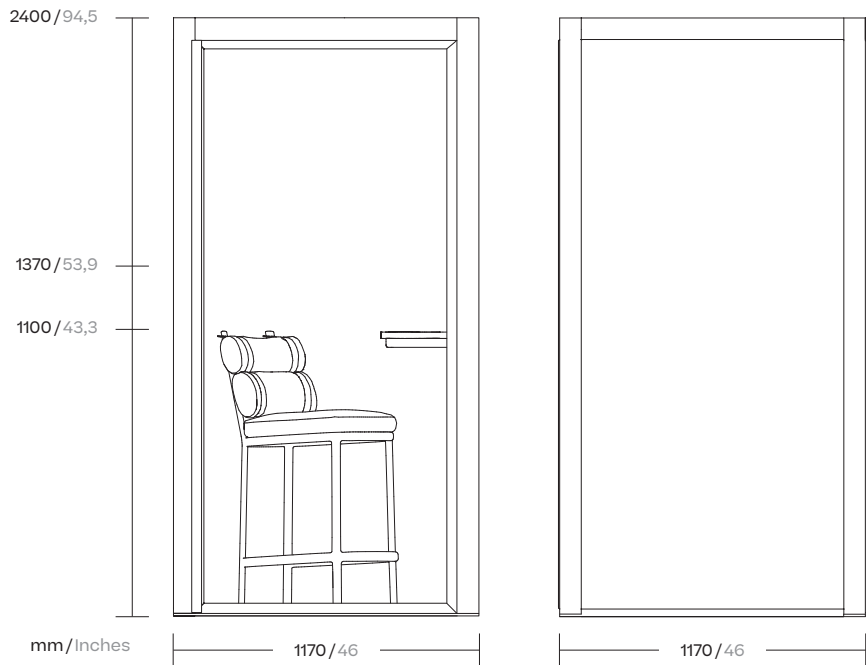

Specifications

- Spring-free door
- Not carpet included
- Aluminium structure
- 2 Fabric sides & 1 ceiling (Relate Fabrics)
- Compact Wood table, shelf & door handle
- Table socket & USB
- Motion sensor PIR
- Power cable (3m)
- LED Track curtain left & right sides
- In / outflow ventilation system 37,4 m³/h
- Glass door
- Entry free space 837 / 33



F



B



G



E



J



I

Phone booth S

Designer
Kettal Studio

Collection
Phone Booth

S Phone Booth 'A' (Fabric in back side)



Phone booth S

Designer
Kettal Studio

Collection
Phone Booth

S Phone Booth 'A' (Fabric in back side)

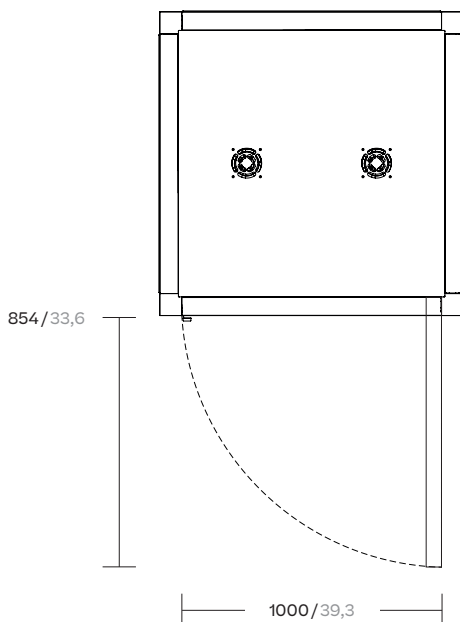
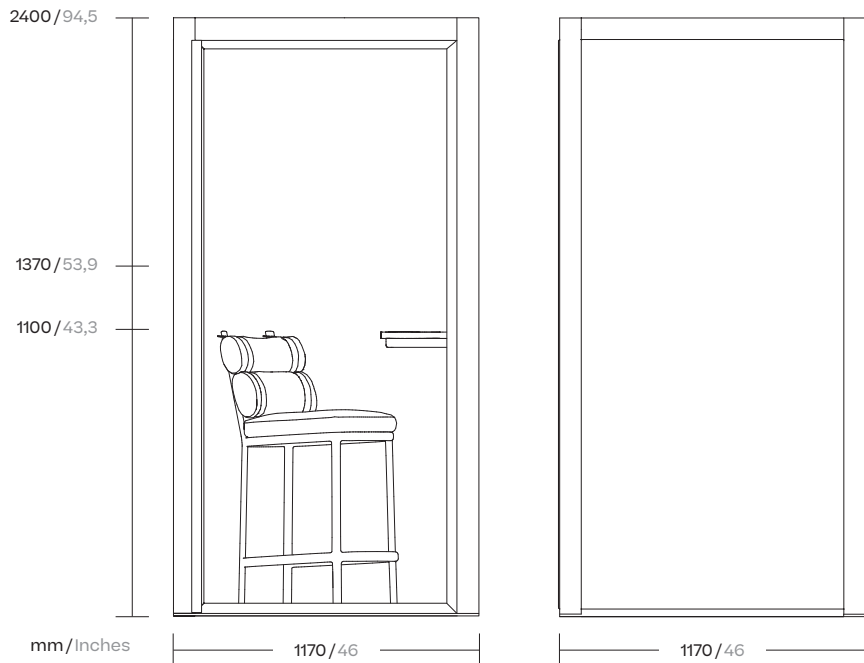

Specifications

- Aluminium structure
- 3 Fabric sides & 1 ceiling (Relate Fabrics)
- Glass door
- Compact Wood table, shelf & door handle
- Table socket & USB
- Motion sensor PIR
- Power cable (3m)
- LED Track curtain left & right sides
- In / outflow ventilation system 37,4 m³/h
- Floor carpet
- Hanger
- Entry free space 837 / 33



F



B



G



E



J



I

* Does not include barstool

Phone booth S

Designer
Kettal Studio

Collection
Phone Booth

S Phone Booth 'B' (Glass in back side)



Phone booth S

Designer
Kettal Studio

Collection
Phone Booth

S Phone Booth 'B' (Glass in back side)

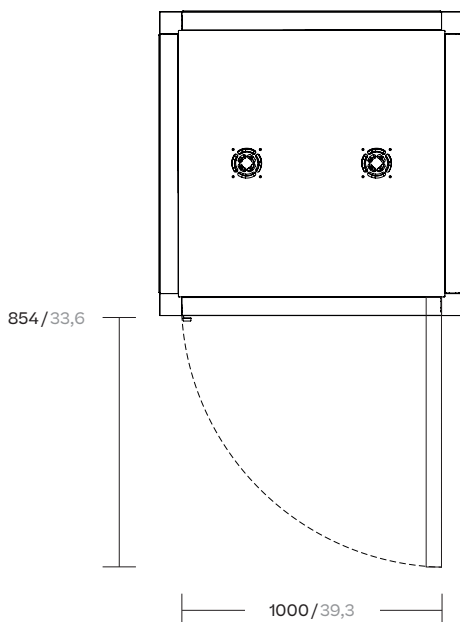
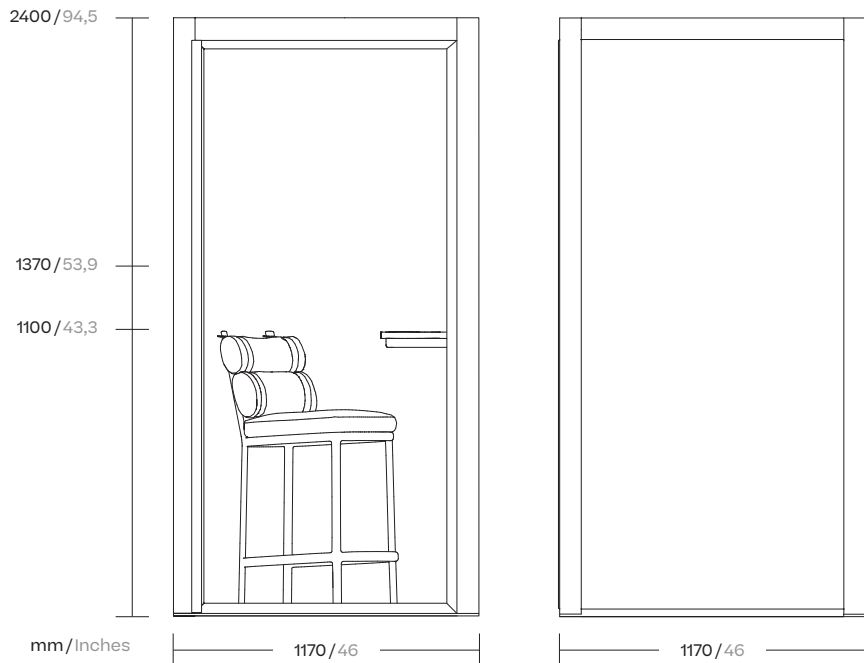

Specifications

- Aluminium structure
- 2 Fabric sides & 1 ceiling (Relate Fabrics)
- 1 Glass panel
- Glass door
- Compact Wood table, shelf & door handle
- Table socket & USB
- Motion sensor PIR
- Power cable (3m)
- LED Track curtain left & right sides
- In / outflow ventilation system 37,4 m³/h
- Floor carpet
- Hanger
- Entry free space 837 / 33



F



B



G



E



J



I

* Bar stool not included

Phone booth L

Designer
Kettal Studio

Collection
Phone Booth

Description

A phone booth with 2 seats.
Convenient to sit down for one-on-one meetings in private. The exceptional acoustics and physical comfort allow for better communication, as well as concentration.

Specifications

- Single or double glazed wall system
- Pivot door
- Metal frame
- Acoustic panels
- Absorption system
- Fabric or glass
- Faced external wall
- Air ventilation system
- LED lighting
- PIR sensor



Phone booth L

Designer
Kettal Studio

Collection
Phone Booth

Version A



Fabric in back side + Sofa O

Version B



Glass in back side glass + Sofa O

Version C



Fabric in back side

Version D



Glass in back side glass

Phone booth L

Designer
Kettal Studio

Collection
Phone Booth

Detailed dimensions

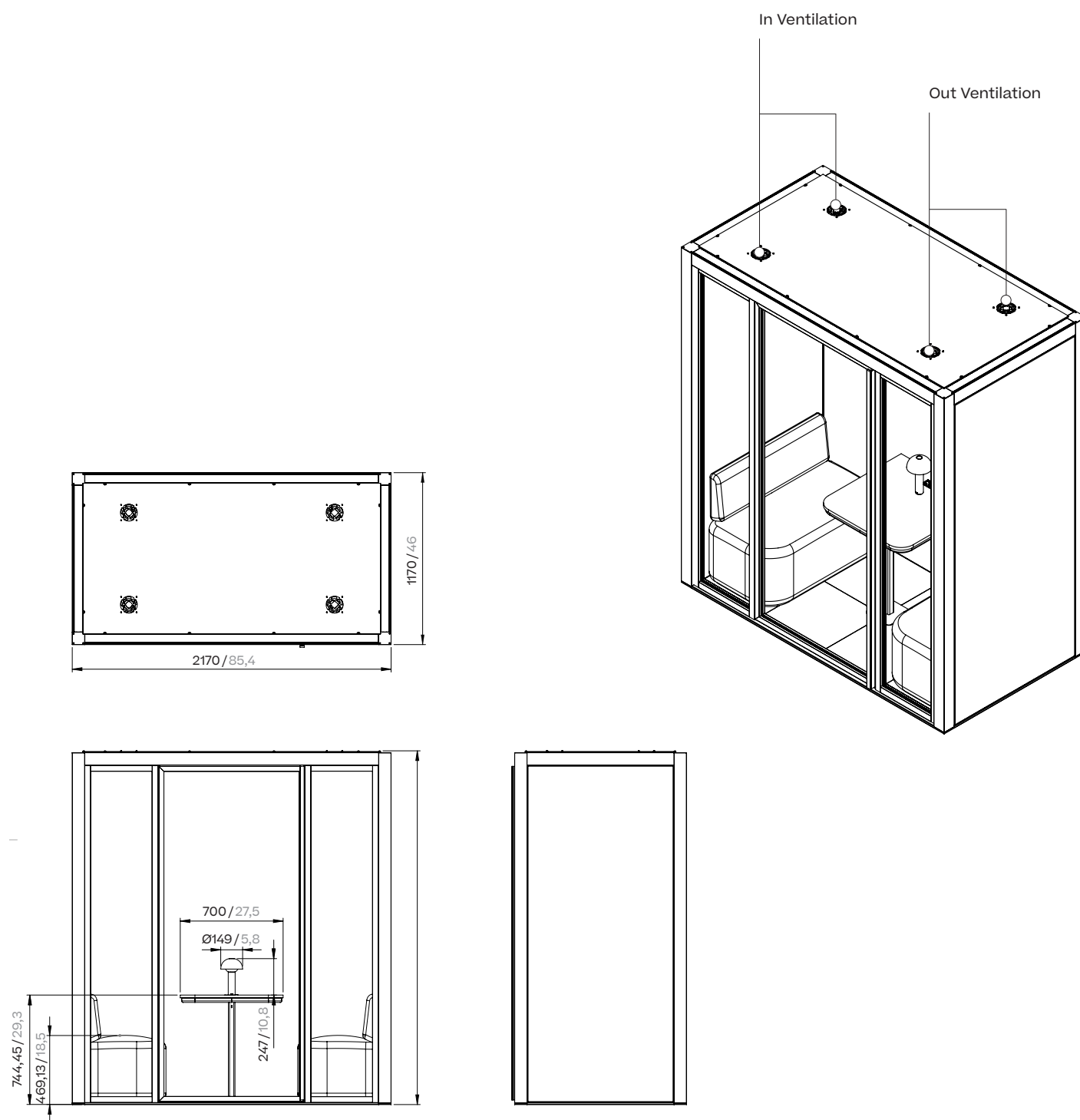

Phone booth L

Designer
Kettal Studio

Collection
Phone Booth

Sofa dimensions

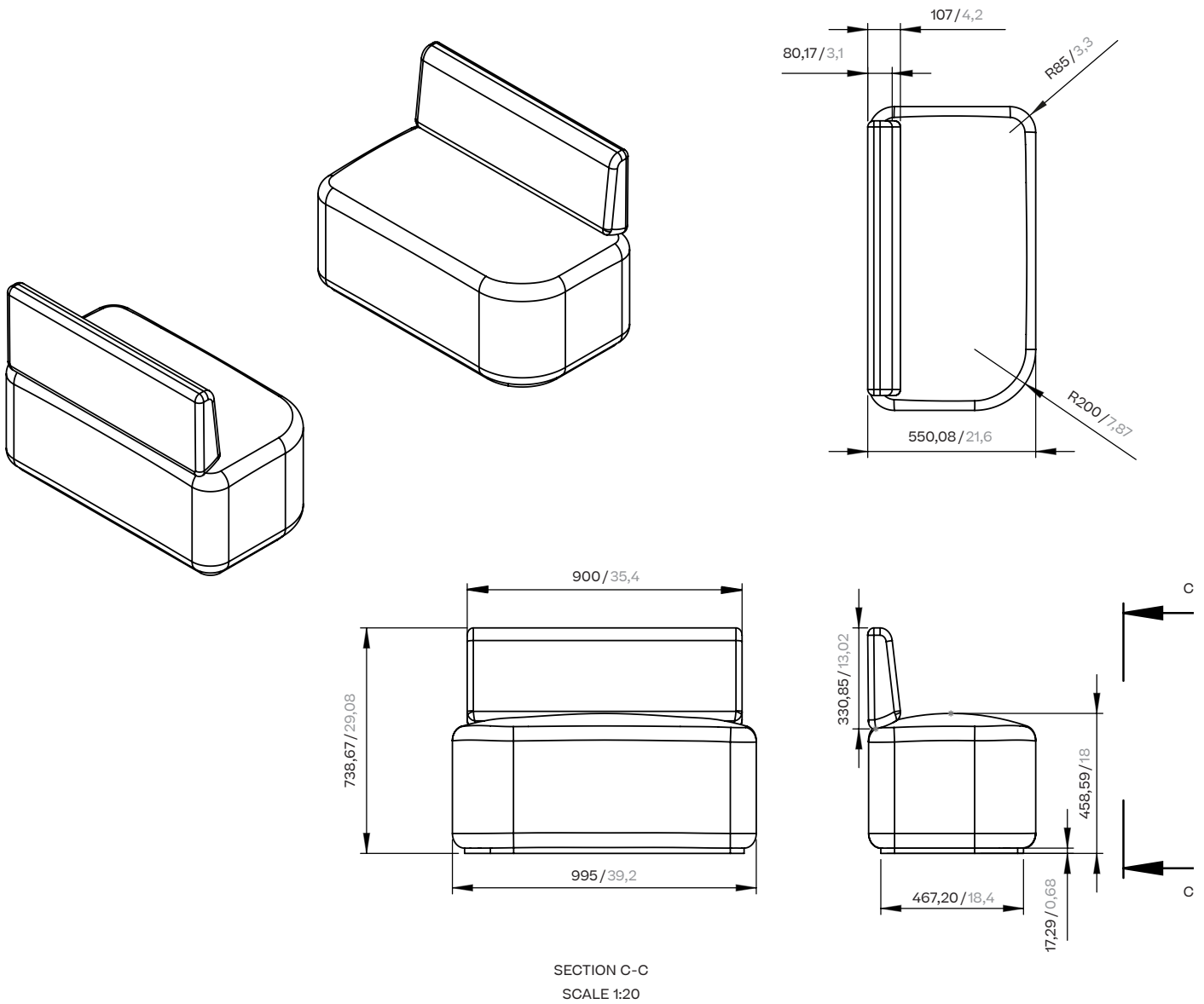

Phone booth L

Designer
Kettal Studio

Collection
Phone Booth

L Phone Booth 2 PAX 'A' (Fabric in back side)



Phone booth L

Designer
Kettal Studio

Collection
Phone Booth

L Phone Booth 2 PAX 'A' (Fabric in back side)

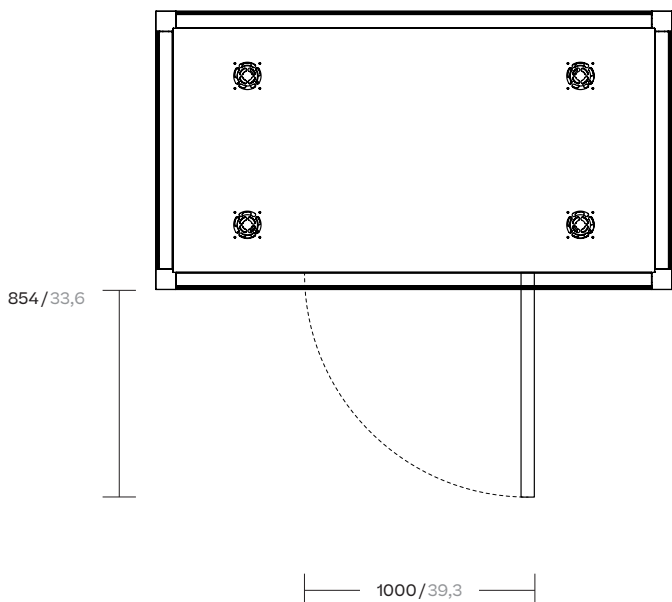
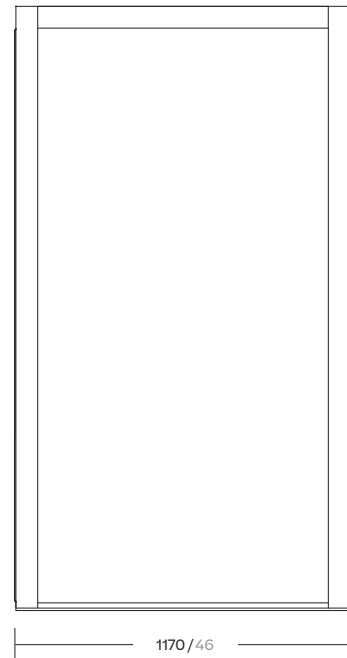
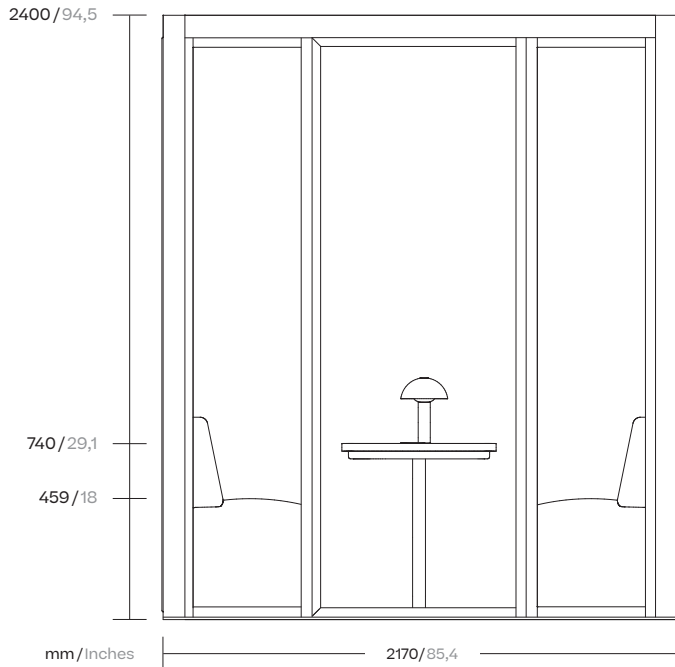

Specifications

- Aluminium structure
- 3 Fabric sides & 1 ceiling (Relate Fabrics)
- Relate fabrics sofas
- Glass door
- Compact Wood table, & door handle
- Table socket & USB
- Motion sensor PIR
- Power cable (3m)
- LED Track curtain back side
- In / outflow ventilation system 74,9 m³/h
- Floor carpet
- Aluminium dot lamp
- Entry free space 837 / 33

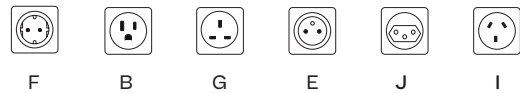

Phone booth L

Designer
Kettal Studio

Collection
Phone Booth

L Phone Booth 2 PAX 'B' (Glass in back side)



Phone booth L

Designer
Kettal Studio

Collection
Phone Booth

L Phone Booth 2 PAX 'B' (Glass in back side)

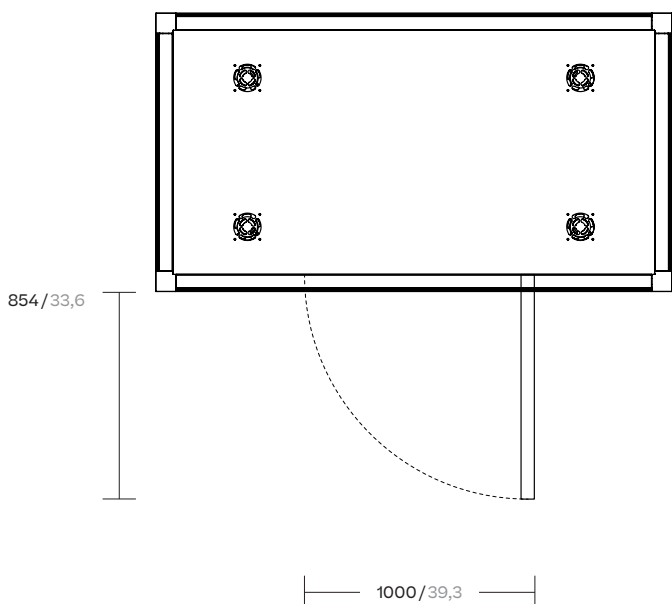
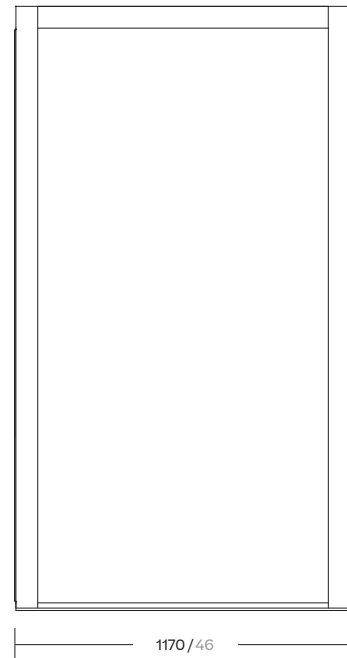
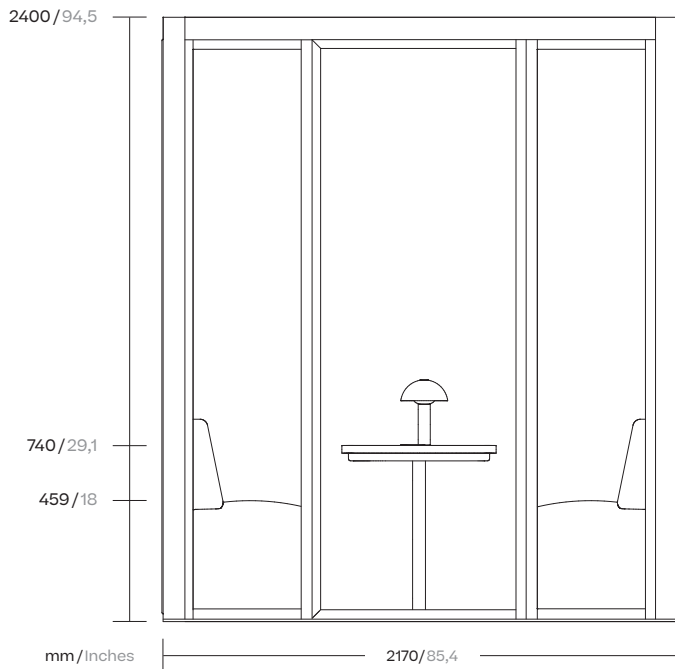

Specifications

- Aluminium structure
- 2 Fabric sides & 1 ceiling (Relate Fabrics)
- Relate fabrics sofas
- 1 Glass panel
- Glass door
- Compact Wood table, & door handle
- Table socket & USB
- Motion sensor PIR
- Power cable (3m)
- LED Track curtain back side
- In / outflow ventilation system 74,9 m³/h
- Floor carpet
- Aluminium dot lamp
- Entry free space 837 / 33

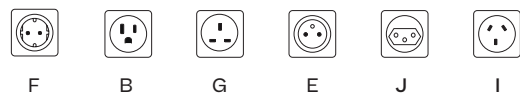

Phone booth L

Designer
Kettal Studio

Collection
Phone Booth

L Phone Booth 2 PAX 'C'. High table (Fabric in back side)



Phone booth L

Designer
Kettal Studio

Collection
Phone Booth

L Phone Booth 2 PAX 'C'. High table (Fabric in back side)

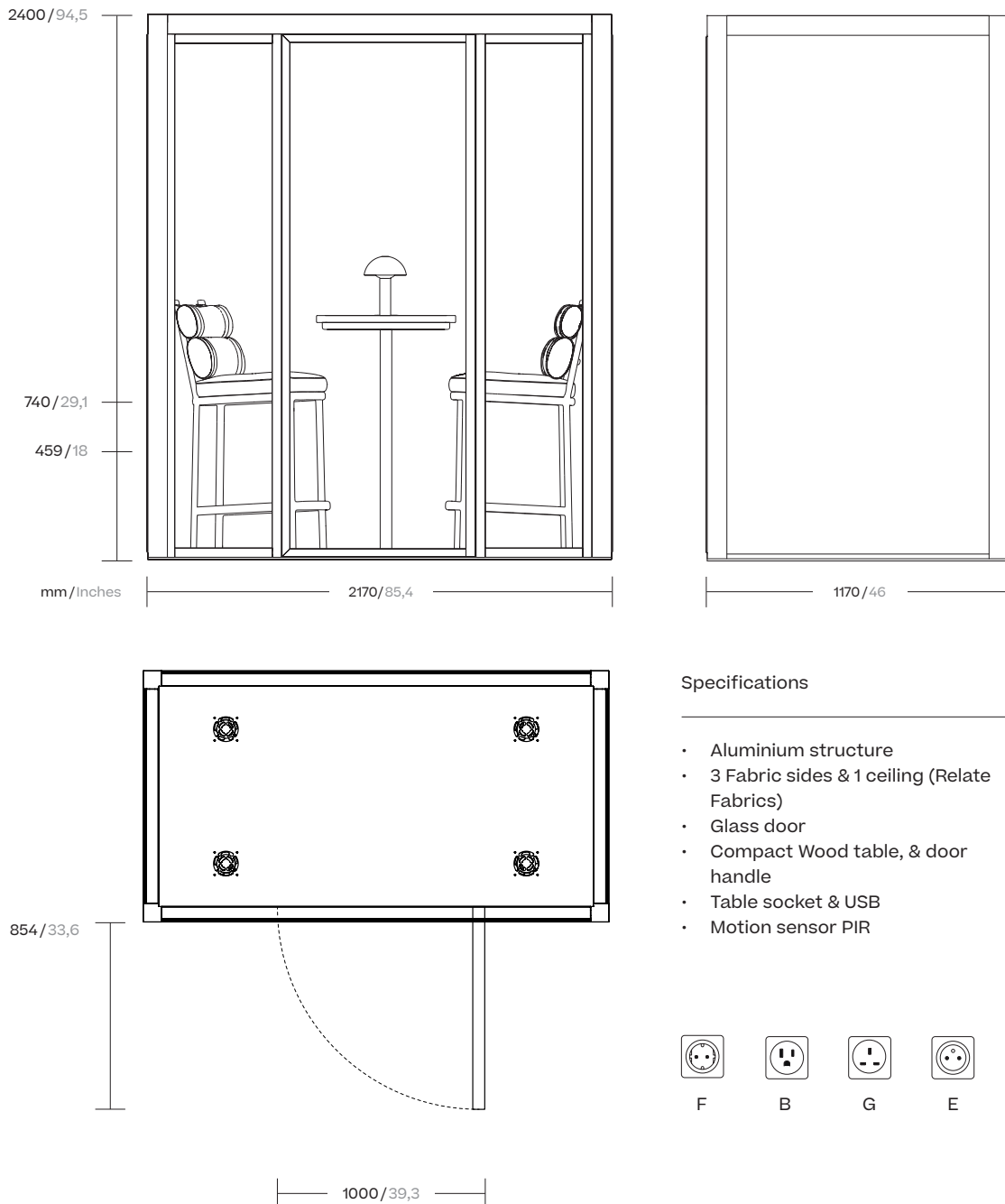

Specifications

- Aluminium structure
- 3 Fabric sides & 1 ceiling (Relate Fabrics)
- Glass door
- Compact Wood table, & door handle
- Table socket & USB
- Motion sensor PIR
- Power cable (3m)
- LED Track curtain back side
- In / outflow ventilation system 74,9 m³/h
- Floor carpet
- Aluminium dot lamp
- Entry free space 837 / 33

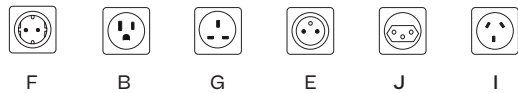

* Stool not included

Phone booth L

Designer
Kettal Studio

Collection
Phone Booth

L Phone Booth 2 PAX 'C'. High table (Fabric in back side)



Phone booth L

Designer
Kettal Studio

Collection
Phone Booth

L Phone Booth 2 PAX 'C'. High table (Fabric in back side)

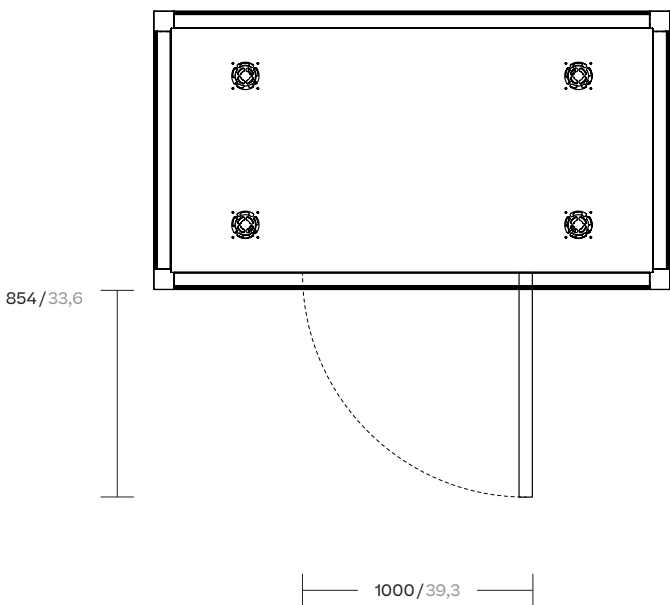
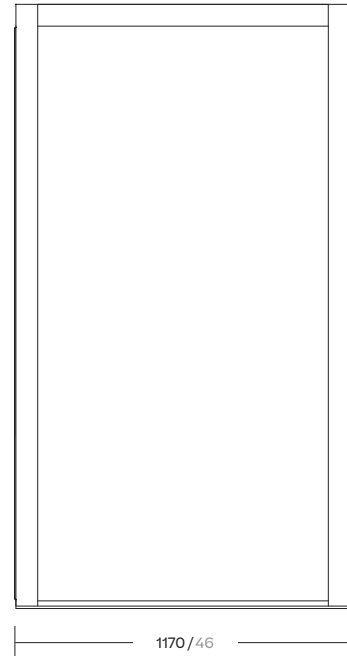
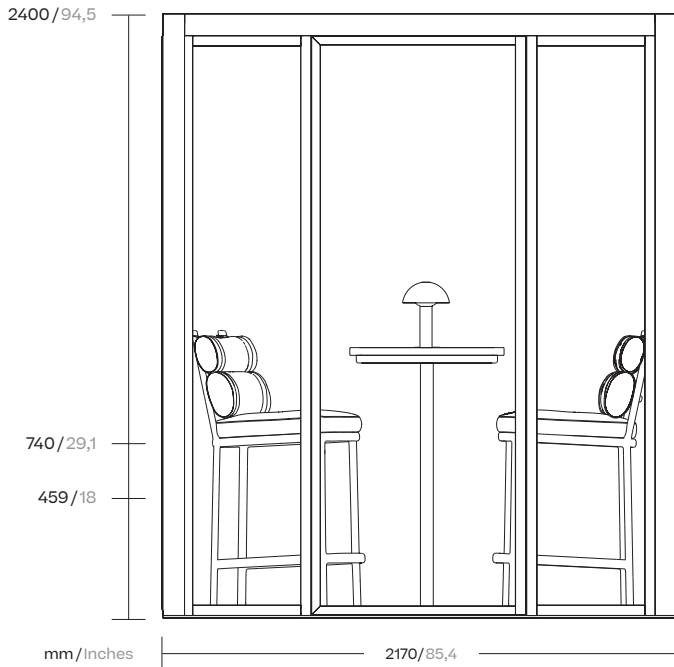

Specifications

- Aluminium structure
- 2 Fabric sides & ceiling (Relate Fabrics)
- 1 Glass panel
- Glass door
- Compact Wood table, & door handle
- Table socket & USB
- Motion sensor PIR
- Power cable (3m)
- LED Track curtain back side
- In / outflow ventilation system 74,9 m³/h
- Floor carpet
- Aluminium dot lamp
- Entry free space 837 / 33

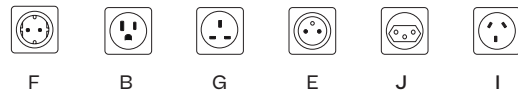

* Stool not included

Phone booth XL

Designer
Kettal Studio

Collection
Phone Booth

Description

A Phone Booth with 4 seats. Ideal for meetings in spacious comfort and privacy. The exceptional acoustics and physical comfort allow for better communication, as well as concentration.

Specifications

- Single or double glazed wall system
- Pivot door
- Metal frame
- Acoustic panels
- Absorption system
- Fabric or glass
- Faced external wall
- Air ventilation system
- LED lighting
- PIR sensor



Phone booth XL

Designer
Kettal Studio

Collection
Phone Booth

Version A



Fabric in back side + Sofa M

Version B



Glass in back side glass + Sofa M

Version C



Fabric in back side

Version D



Glass in back side glass

Phone booth XL

Designer
Kettal Studio

Collection
Phone Booth

Detailed dimensions

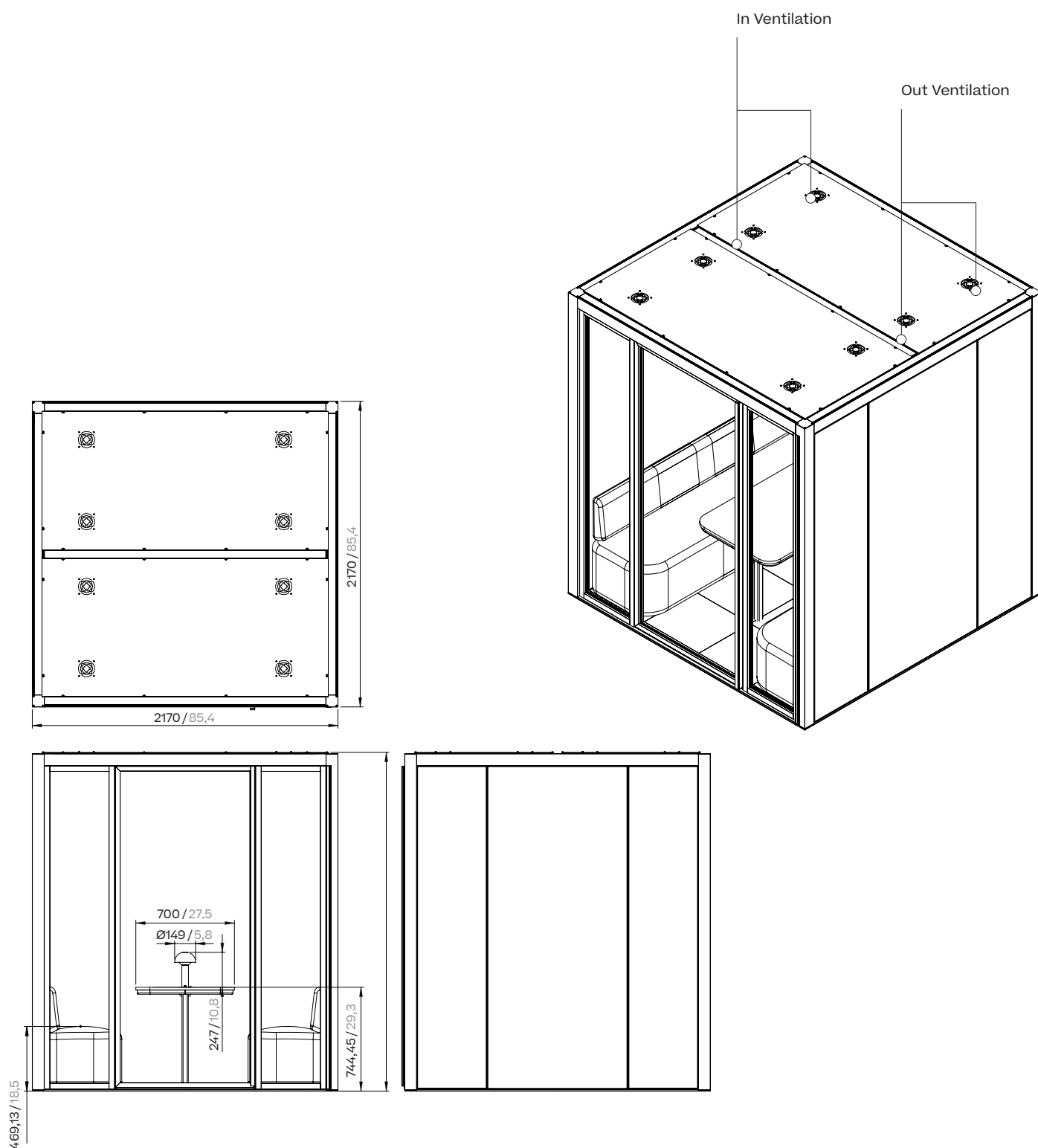

Phone booth XL

Designer
Kettal Studio

Collection
Phone Booth

Table. Detailed dimensions

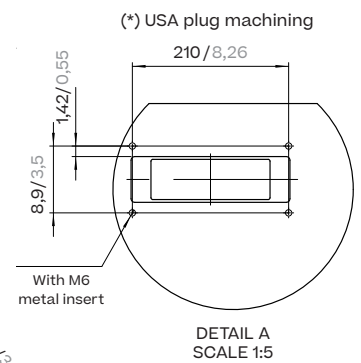
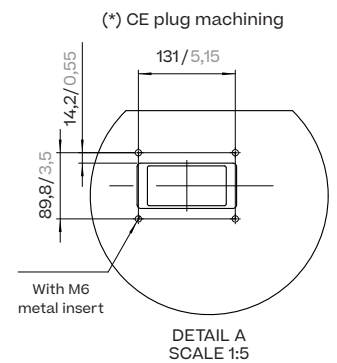
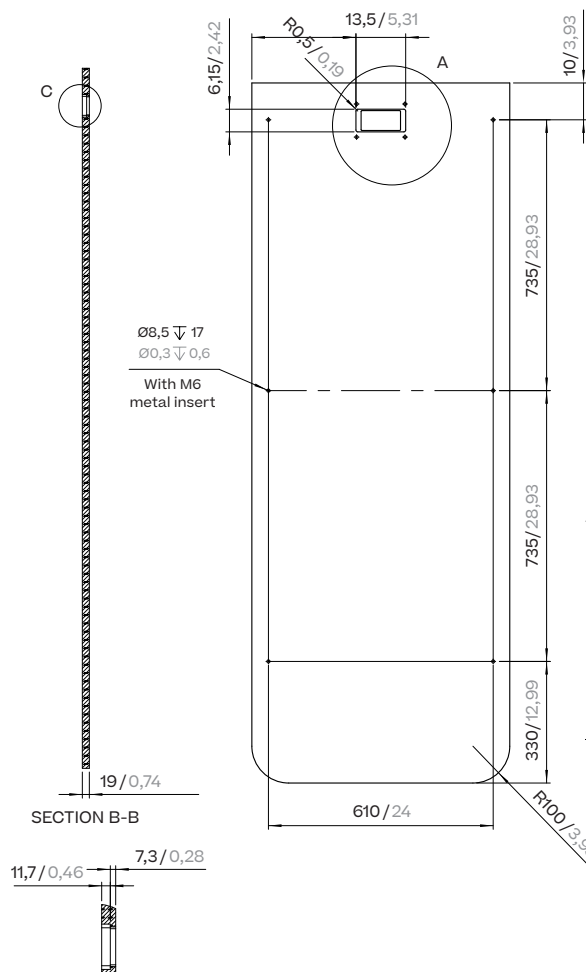
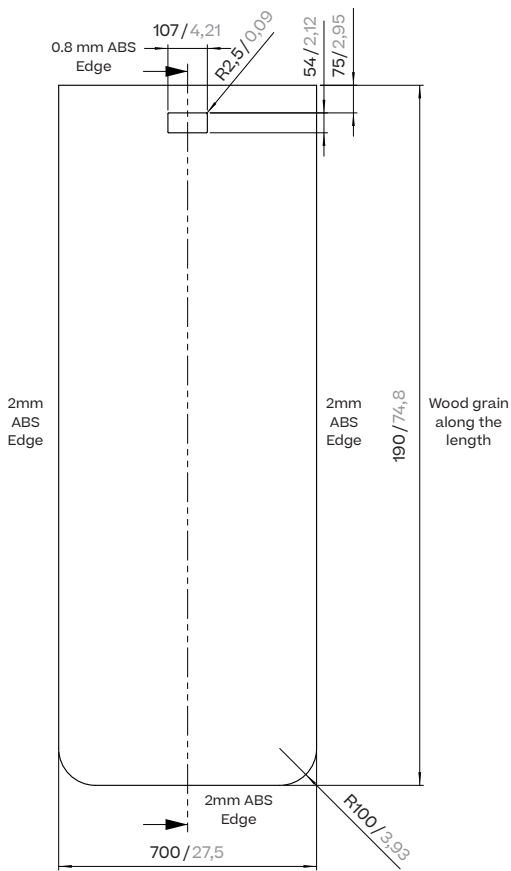
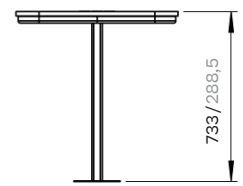
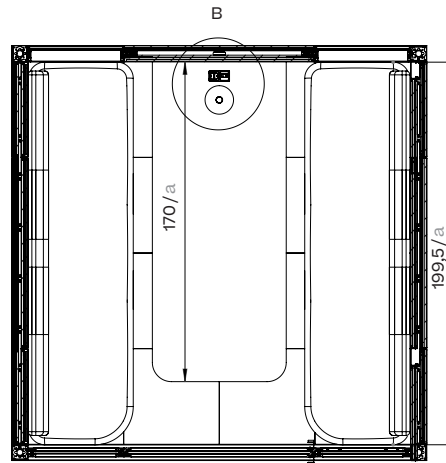
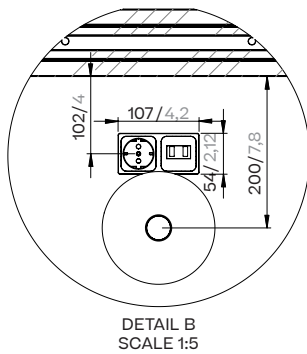

Phone booth L

Designer
Kettal Studio

Collection
Phone Booth

XL Phone Booth 4 PAX 'A' (Fabric in back side)



Phone booth L

Designer
Kettal Studio

Collection
Phone Booth

XL Phone Booth 4 PAX 'A' (Fabric in back side)

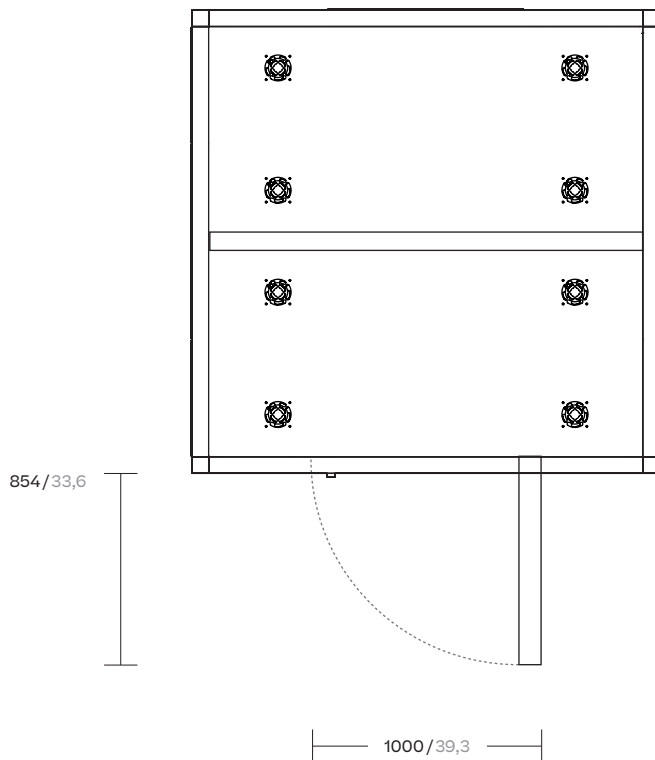
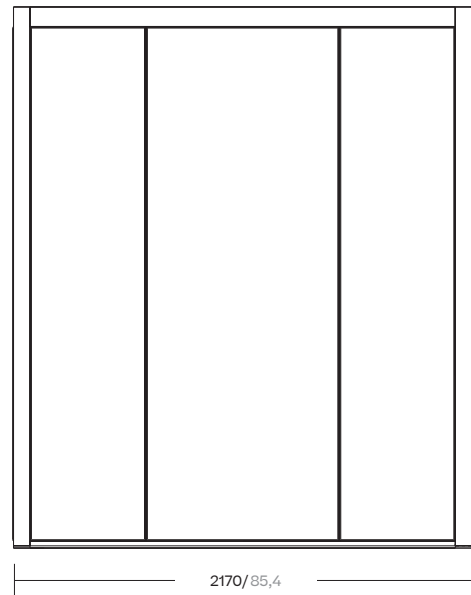
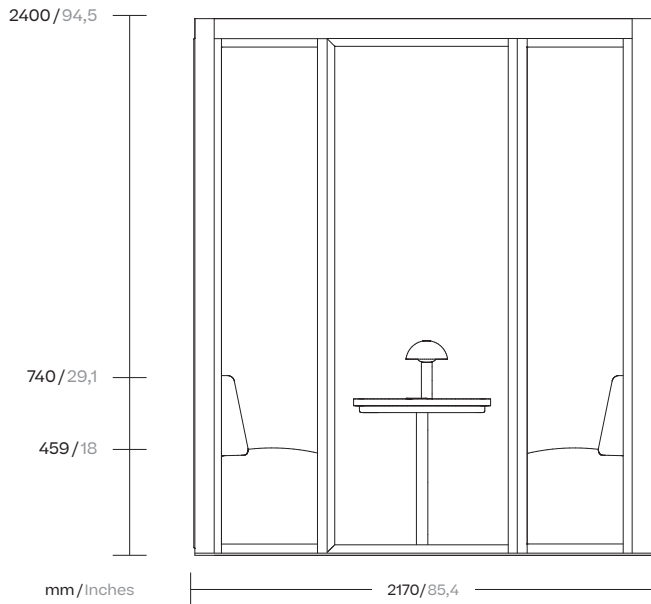

Specifications

- Aluminium structure
- 3 Fabric sides & 1 ceiling (Relate Fabrics)
- Relate fabrics sofas
- Glass door
- Compact Wood table, & door handle
- Table socket & USB
- Motion sensor PIR
- Power cable (3m)
- LED Track curtain back side
- In / outflow ventilation system 149,8 m³/h
- Floor carpet
- Aluminium dot lamp
- Entry free space 837 / 33



F



B



G



E



J



I

Phone booth L

Designer
Kettal Studio

Collection
Phone Booth

XL Phone Booth 4 PAX 'B' (Glass in back side)



Phone booth L

Designer
Kettal Studio

Collection
Phone Booth

XL Phone Booth 4 PAX 'B' (Glass in back side)

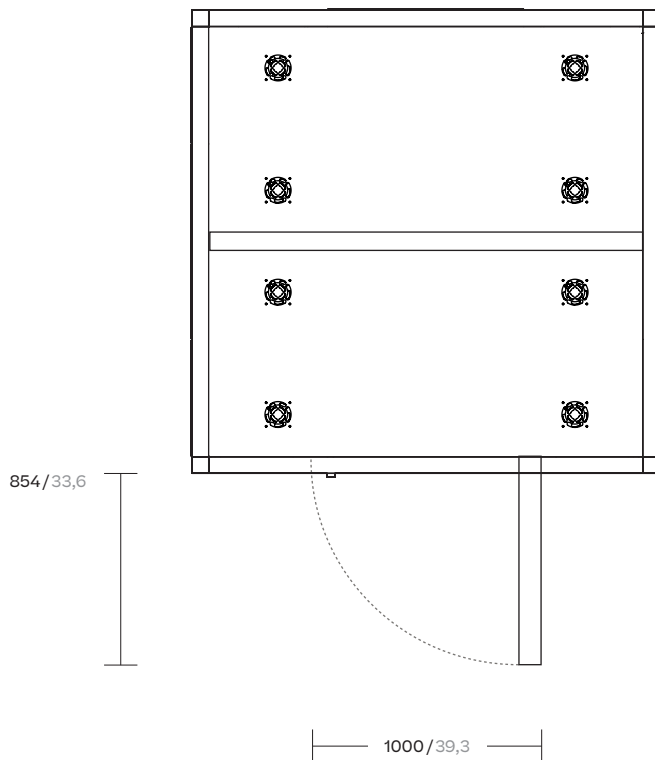
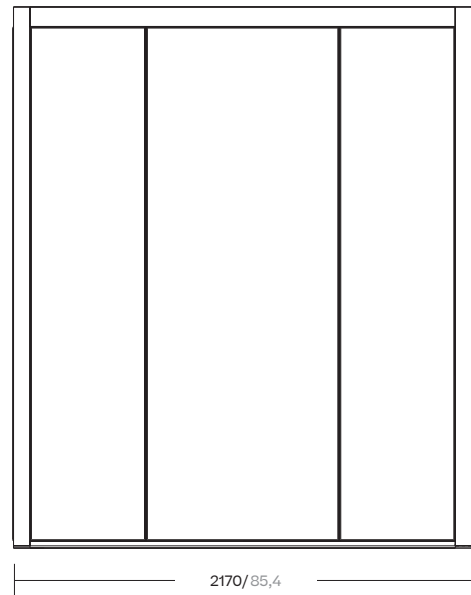
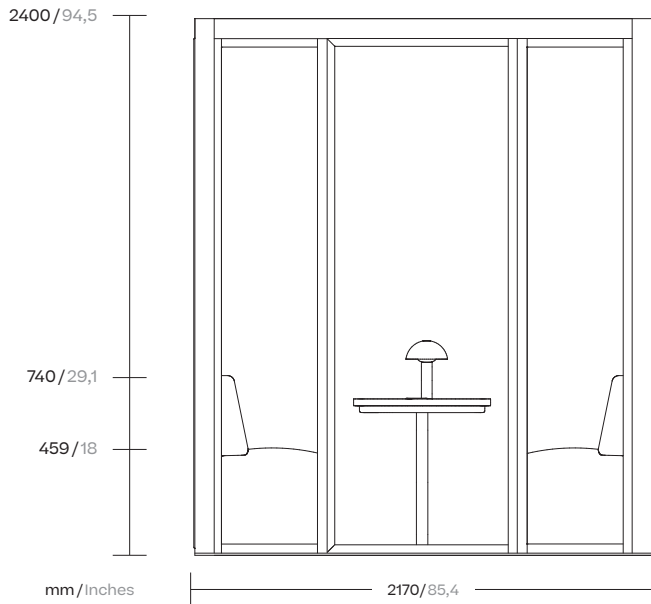

Specifications

- Aluminium structure
- 2 Fabric sides & 1 ceiling (Relate Fabrics)
- Relate fabrics sofas
- 1 Glass panel
- Glass door
- Compact Wood table, & door handle
- Table socket & USB
- Motion sensor PIR
- Power cable (3m)
- LED Track curtain back side
- In / outflow ventilation system 149,8 m³/h
- Floor carpet
- Aluminium dot lamp
- Entry free space 837 / 33



F



B



G



E



J



I

Phone booth L

Designer
Kettal Studio

Collection
Phone Booth

XL Phone Booth 4 PAX 'C'. High table (Fabric in back side)



Phone booth L

Designer
Kettal Studio

Collection
Phone Booth

XL Phone Booth 4 PAX 'C'. High table (Fabric in back side)

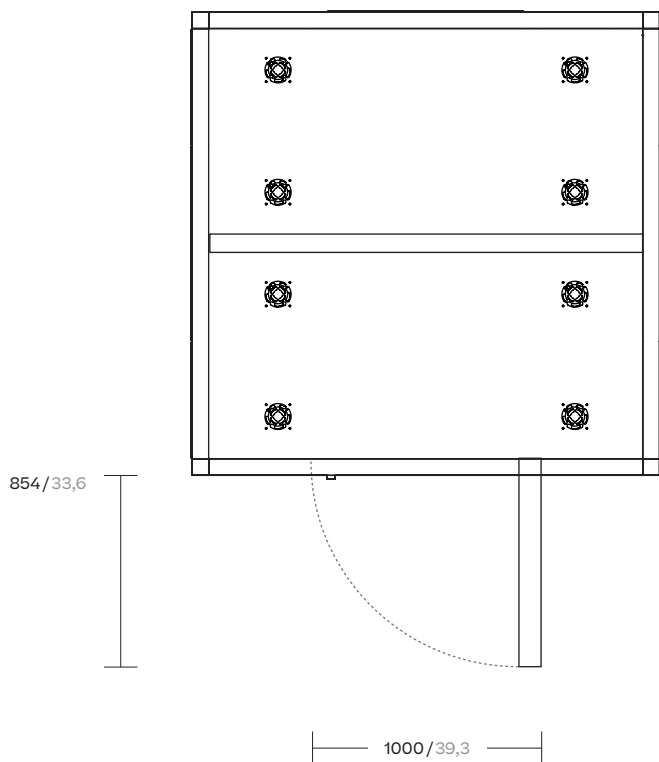
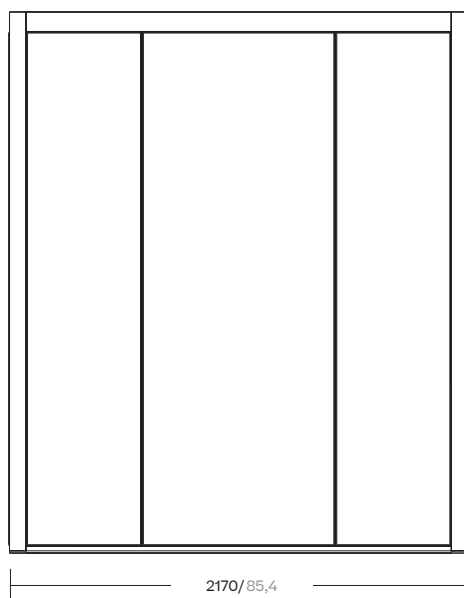
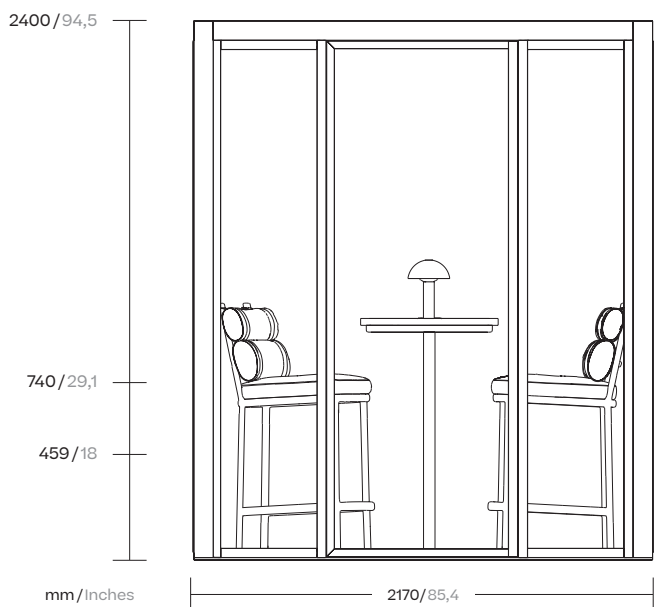

Specifications

- Aluminium structure
- 3 Fabric sides & 1 ceiling (Relate Fabrics)
- Relate fabrics sofas
- Glass door
- Compact Wood table, & door handle
- Table socket & USB
- Motion sensor PIR
- Power cable (3m)
- LED Track curtain back side
- In / outflow ventilation system 149,8 m³/h
- Floor carpet
- Aluminium dot lamp
- Entry free space 837 / 33



F



B



G



E



J



I

Phone booth L

Designer
Kettal Studio

Collection
Phone Booth

XL Phone Booth 4 PAX 'D'. High table (Glass in back side)



Phone booth L

Designer
Kettal Studio

Collection
Phone Booth

XL Phone Booth 4 PAX 'D'. High table (Glass in back side)

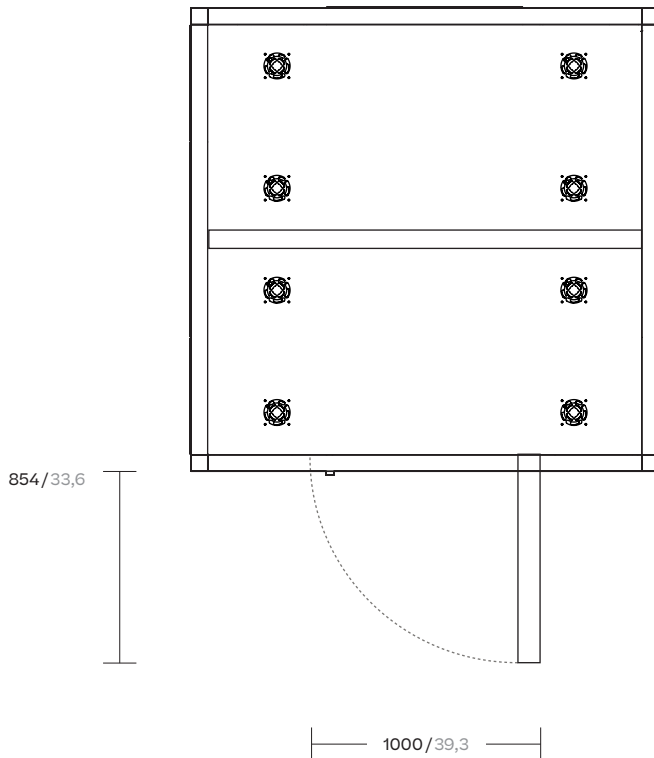
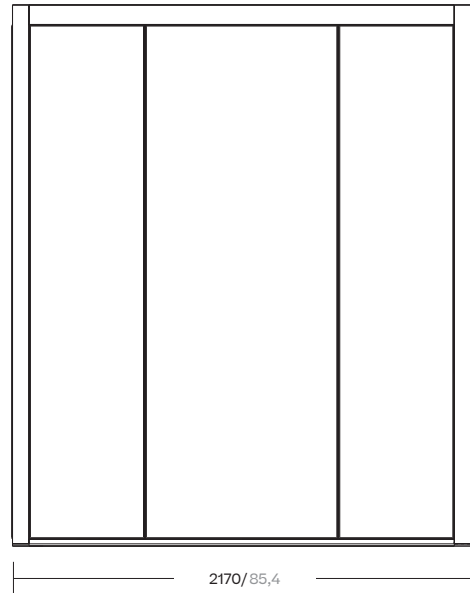
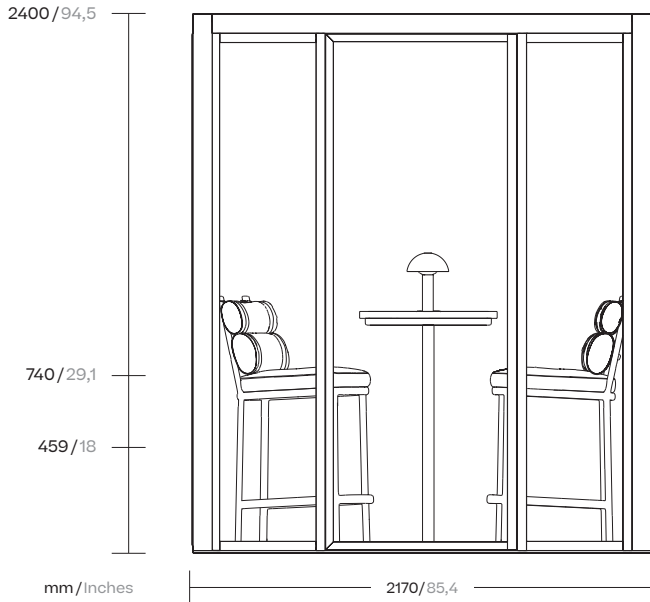

Specifications

- Aluminium structure
- 2 Fabric sides & 1 ceiling (Relate Fabrics)
- Relate fabrics sofas
- 1 Glass panel
- Glass door
- Compact Wood table, & door handle
- Table socket & USB
- Motion sensor PIR
- Power cable (3m)
- LED Track curtain back side
- In / outflow ventilation system 149,8 m³/h
- Floor carpet
- Aluminium dot lamp
- Entry free space 837 / 33



F



B



G



E



J



I

Phone booth, Technical specifications

kettal

LED Track Curtain

A recessed lighting system equipped with an LED light source. Specially designed for wall-washer lighting, the LED Curtain incorporates lenses to provide optimum light distribution. The LED Curtain range is available in different lengths which means it can be adjusted to suit any space, while its compact size facilitates simple integration within the Phone booth system.



4,7/1,8 



Cm/Inches



Table mounted outlets

Technical specifications

Designer
Kettal Studio

Collection
Phone Booth

Hardware

- Simple design
- Power Connections
- USB A + USB C
- Plug and outlet types (UK, FRA, US, SUI, AUS,...)

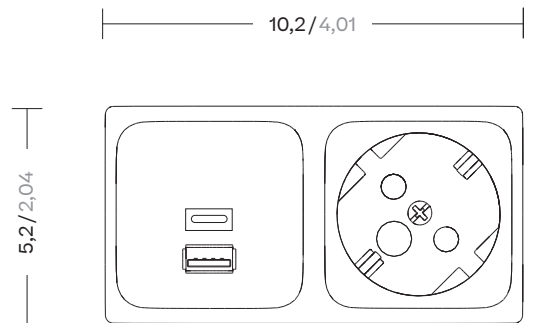

cm/Inches



Phone booth,
Acoustics

kettal

Description

All our panels are tested to ensure they meet the required acoustic levels. We have tested some of the wall combinations to provide guidelines with regard to acoustic levels. Acoustic performance varies depending on the material selection for each wall.

The M glass version offers excellent acoustic performance, creating a comfortable and efficient working environment. It is based on 3+3 and 6+6 laminates with a soundproofing membrane to provide an impressive acoustic performance of up to 44dB. We also offer a range of solid wall options in fabric and wood. Many of these alternative wall options offer excellent acoustic performance properties. Our laminated panels not only provide additional acoustic performance, but also come in a range of colors. As a result, you can customize your Pavilion M to reflect your brand image or simply to create a bright office space. In addition, the eco-friendly panels reduce and control reverberated noise within the Pavilion, further enhancing the overall soundproofing performance.

Key functions

- All materials are fire retardant M1
- Memory acoustic foam
- Easy clean material
- Odor free and antimicrobial

Acoustic plus

Fabric

Super panel 10 mm

Soundproofing membrane

Geopanel

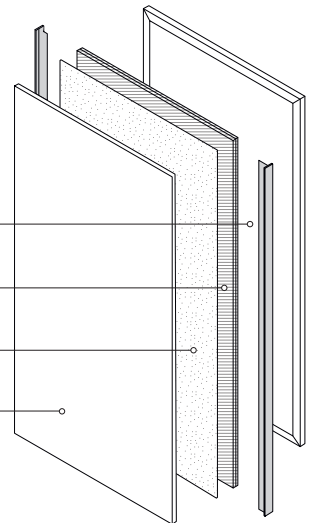

Acoustic comfort

Fabric

PET

Super panel 10 mm

Geopanel 10 mm

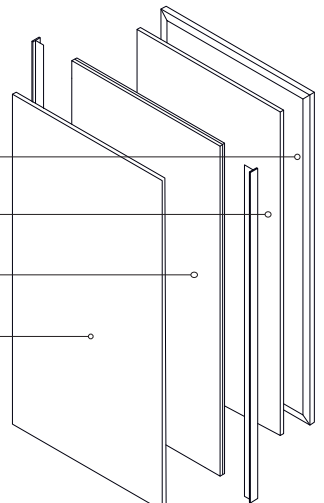

Acoustic panels

Acoustics

Designer
Kettal Studio

Collection
Phone Booth

Acoustic Panel Comfort (36 dB)

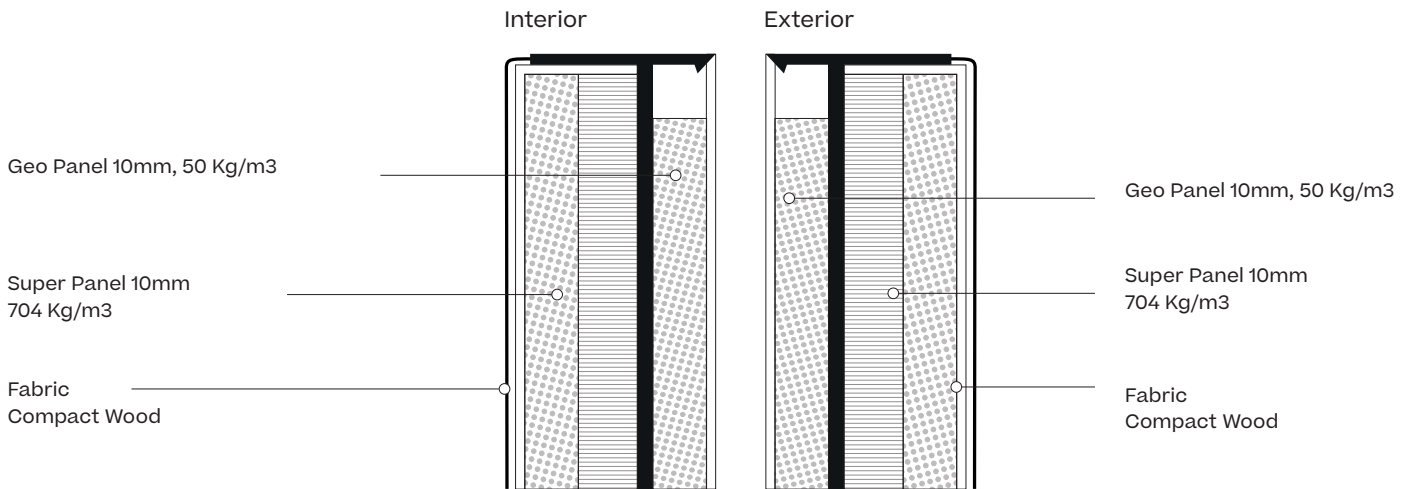

Acoustic Panel Plus (41 dB)

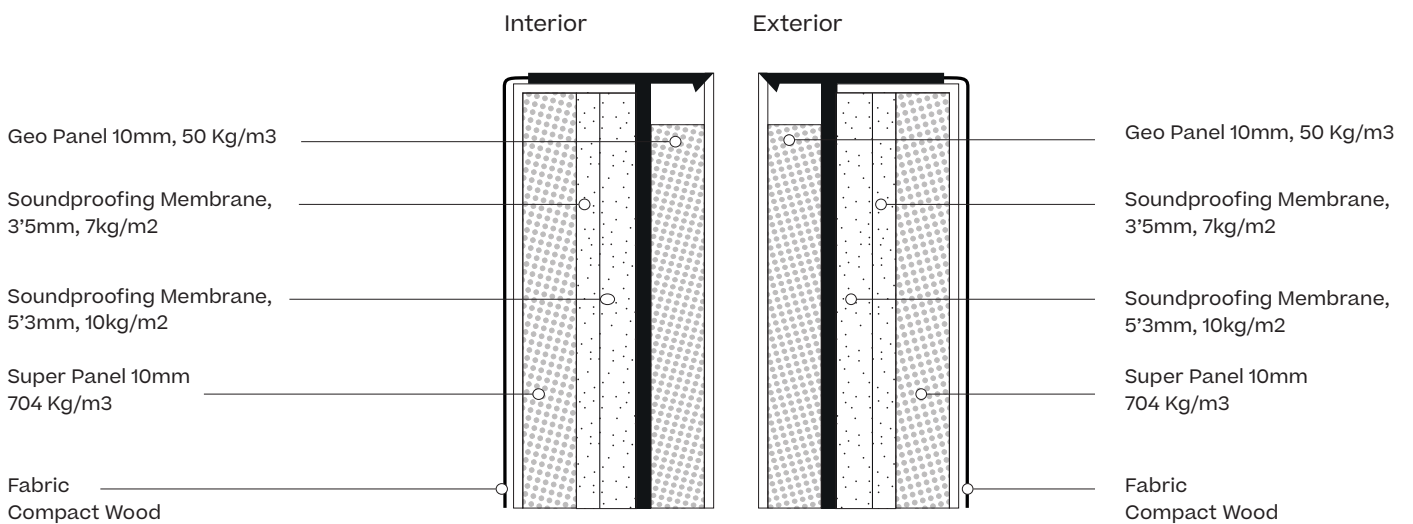

Acoustic panels

Acoustics

Designer
Kettal Studio

Collection
Phone Booth

Acoustic Glass Comfort (34 dB) / Plus (38 dB)

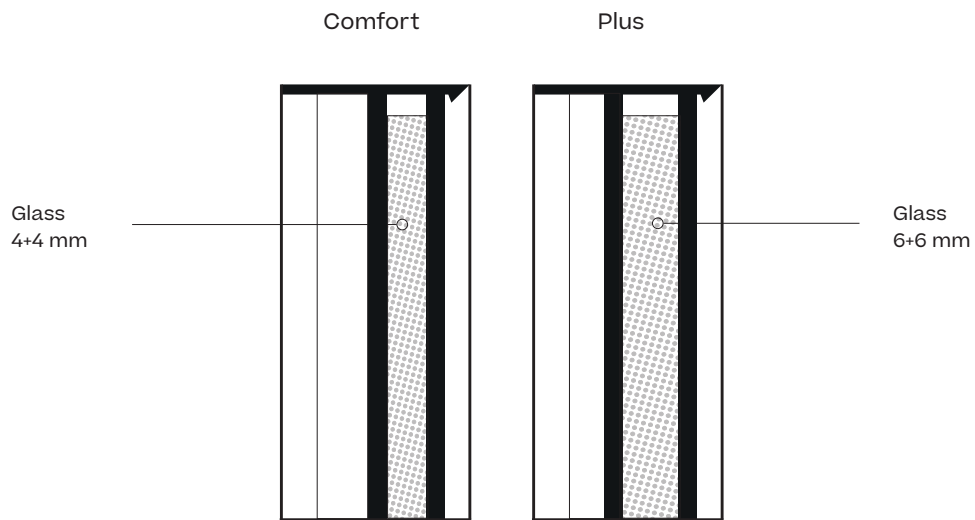

Nuvola / PET Acoustic Ceiling

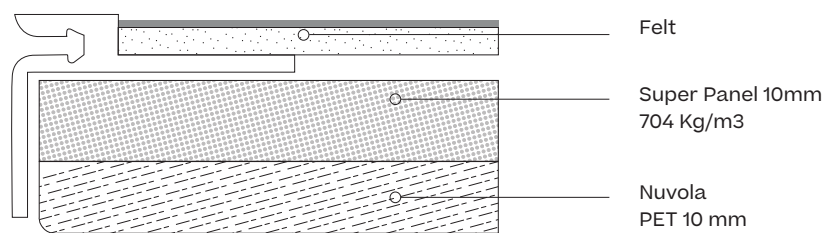

Acoustic panels

Acoustics

Designer
Kettal Studio

Collection
Phone Booth

Ceiling Panel Nuvola

28 dBA

Sound reduction index, R [dB]

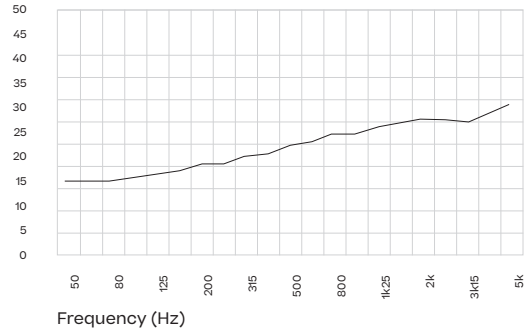

Acoustic ceiling

$R_w (C;Ctr)=30(-2;-4)$ dB
 $R_A = 28$ dBA

Acoustic Side Panel

Comfort Plus

36/41 dBA

Sound reduction index, R [dB]

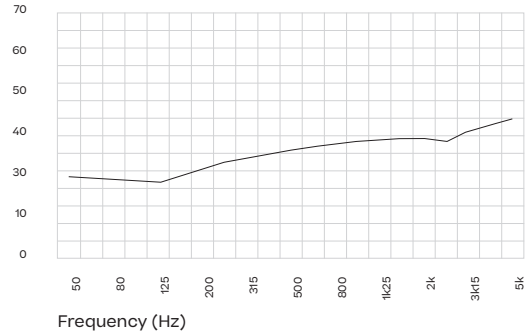

Plus Acoustic side panel

$R_w (C;Ctr)=45(-4;-11)$ dB
 $R_A = 41$ dBA

Acoustic Glass & Glass Door

Comfort Plus

34/38 dBA

Sound reduction index, R [dB]

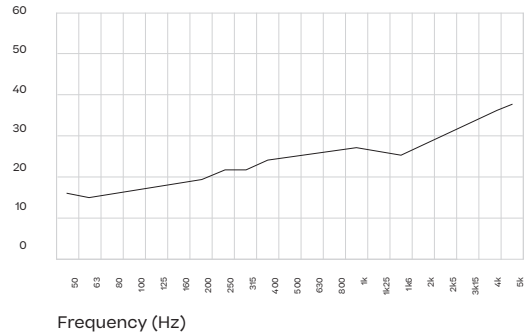

Comfort Acoustic Glass
4+4 mm - inch

Plus Acoustic Glass
6+6 mm - inch

$R_w (C;Ctr)=39(-1;-3)$ dB
 $R_A = 38$ dBA

Average reverberation

0,2 RT

Sound reduction index, R [dB]

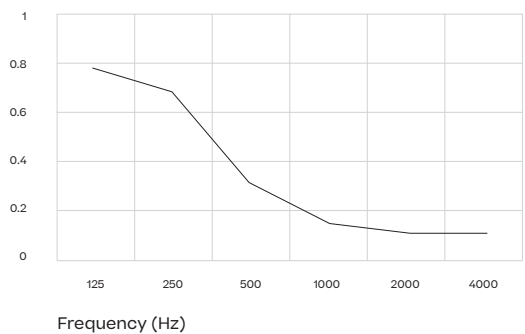

Plus Acoustic Glass

0.2 RT

Phone booth
Aesthetics & materiality

kettal

Structural Aluminium

Extruded and hollow profiles of this alloy will be used to build up the structures of each booth.

This is a light and ductile alloy, with great strength and magnificent finishing characteristics. It is ideal for works that require high quality and perfect finishes.

It has excellent corrosion resistance, similar to that of stainless steel. Follows the UN-EN-AW 10204 3-1 regulation.

Kettal uses 80% recycled aluminum in the extrusion of its profiles in order to reduce greenhouse gases, thus contributing to a more sustainable production of our customers' products.

Chemical composition (UN-EN 10204 3-1 Regulation)

%	Min. Máx.
Si	0.30 0.60
Fe	0.10 0.30
Cu	- 0.10
Mn	- 0.10
Mg	0.35 0.60
Cr	- 0.05
Zn	- 0.15
Ti	- 0.10



Recyclable



80%
recycled



Local supplier

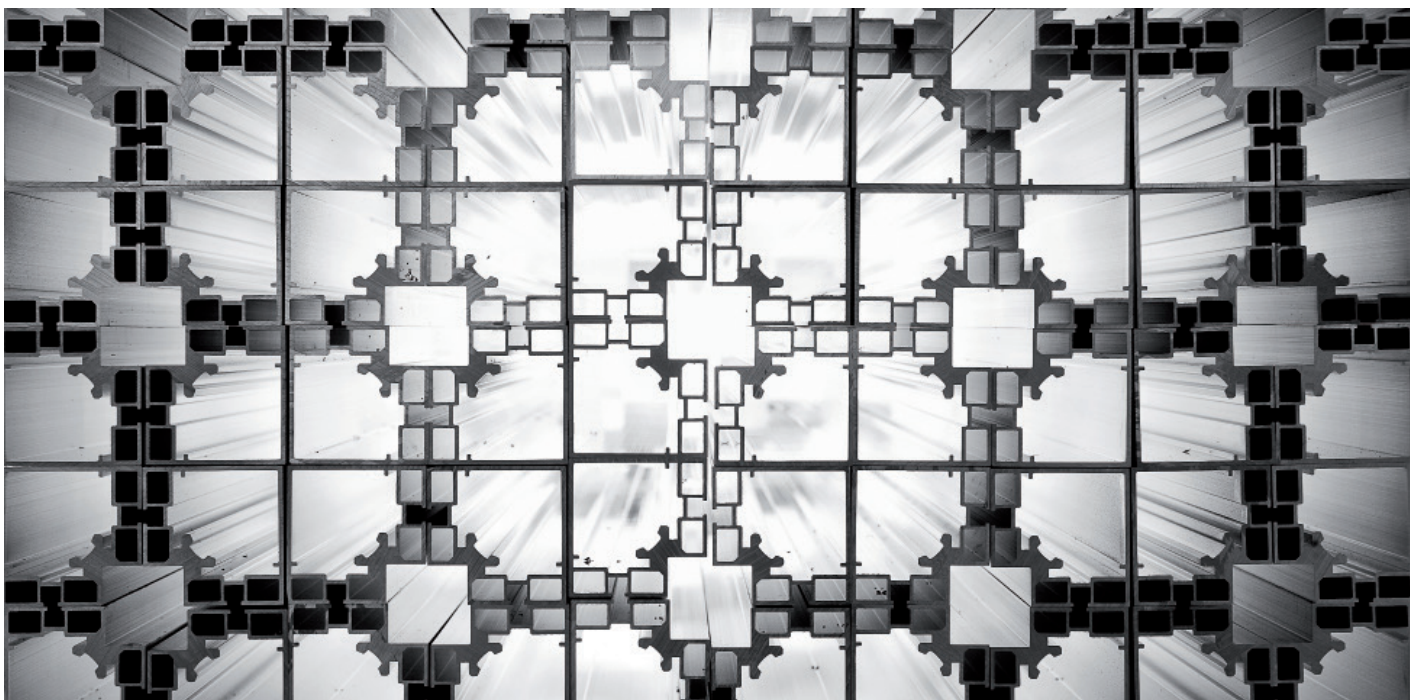

Technical wood

The technical wood is one of the main components to create the acoustic lateral panel and ceiling. 10mm fire-fighter. Complies with E1 regulation

The environmental product declaration is in accordance with ISO 14025 and EN 15804.

Comply with standards EN 622- 1, EN 622-5 and EN 14322. They are considered reliable products used as raw material for the construction and furniture industry.

Characteristics	Test	Units
Density	EN 323	kg/m3
Flexural strength	EN 310	N/mm2
Formaldehyde emission	EN 717-1	ppm
Reaction to fire	EN 13501-1	Euroclase
Absorption acoustic coefficient	UNE EN 13986:2006+A 1 :2015	α
Acoustic insulation	UNE EN 13986:2006+A 1 :2015	db
Biological durability	UNE EN 335	Clase de uso



Type 2
From cradle to gate with options



Local supplier



Formaldehyde free



Soundproof Safety Glass

6 mm / 1 PVB / 6 mm

Soundproof safety glass, consists of two or more glass sheets joined by one or more Polyvinyl Butiral (PVB) films,

Direct acoustic isolation 39 dB.

If a laminated glass is broken, the PVB film retains a large part of the glass fragments, that is, the residual strength and the maintenance of the glazing are kept in the same place until they are replaced.

These glasses filter 99% of the UV rays and contribute to extend the life of curtains, rugs, fabrics, objects, etc., which are exposed daily to natural light.

It offers protection against a need for security and complies with the requirements of current norms and regulations, both for homes, shops or offices.

In case of breakage, the fragments remain attached to the sheet.

Chemical composition

SiO ₂	69 - 74 %
Na ₂ O	10 - 16 %
CaO	5 - 14 %
MgO	0 - 6 %
Al ₂ O ₃	0 - 3 %
Others	0 - 5 %



Belgian
supplier



Soundproof
safety glass



Terrain Paints

Terrain Paints are designed for aluminum profile coatings used in architecture and for other substrates where maximum outdoor resistance is needed.

It is a powder coating formulated with polyester resins and free of TGIC, pigments and additives. They offer excellent exterior durability with very good gloss retention and color stability.

Certificates



Class A2



Polymerization
at 160°



Local supplier



Materials

Aesthetics & Materiality

Designer
Kettal Studio

Collection
Phone Booth

Terrain Paints

Characteristics	Min.	Max.	Method
Baking time / temperature	24 to 150 °C / 75,2 to 302 °F	26 to 150 °C / 78,8 to 302 °F	Total time
Gloss at 60° angle	6	9	ISO 2813
Direct impact 12.5 mm	30		ISO 2813
Indirect impact 12.5 mm	30		ISO 2813
Cross-cut adhesion	0	0	ISO 2813
Erichsen Cupping test	5	11	ISO 2813
Bend test (Cylindrical Mandrel)		6	ISO 2813
Avg. Particle size	50	55	MALVERN
Particle size % < 100 MICRONS	80	95	MALVERN
Particle size % < 50 MICRONS	50	65	MALVERN
Particle size % < 10 MICRONS	4	8	MALVERN
Delta E colour		VISUAL	CIELAB
General appearance	Textured		NIZI-001

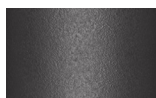

Slate Stone
01C

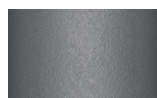

Mystic Smoke
02C



Ash
03C



Bone
04C

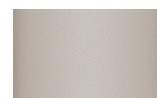

Tuff
05C



Wet Stone
06C



Sand Dune
07C



Dry Clay
08C



Arabica
09C



Sepia
19C



Rose Canyon
16C



Blossom
20C



Ruby Dust
18C



Sunset Glow
17C



Terrarosa
15C



Terracota
14C



Amber
13C



Ginger Root
12C



Desert Storm
11C



African
Savannah 10C

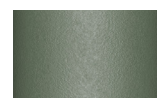

Spring Meadow
28C

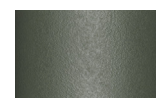

Kombu
29C



Forest Stream
27C



Sea Moss
26C



Glacier Ice
25C



Polar Sky
24C



Nightfall
23C



Indigo
22C



Wild Lupin
21C

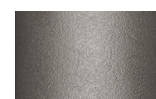

Galena
33C



Bronze
30C



Corten
31C

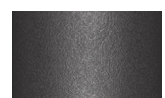

Manganese
32C

Kvadrat Relate Fabrics

Relate is a sophisticated twill weave upholstery textile designed by Patricia Urquiola made from Trevira CS, which has a soft hand resembling natural fibres.

The versatile palette for Relate comprises 35 colourways and expresses confident colour combinations by combining warm notes with closely related nuances.

Relate is suitable for contract and private use.



Suitable for indoor use only

Regular care

Regular cleaning is important in order to keep the upholstery textile looking its best and to prolong its life. Dust and dirt wear down the textile and also reduce its re-retardant properties.

Vacuum frequently, ideally every week, at half power where appropriate. Wipe upholstery fabrics made from polyurethane with a dry or moist cloth. May also be vacuum cleaned with a soft brush.

Care instructions



Technical specifications

Composition	100% Trevira
Width	Approx. 140 cm
Weight per m ²	Approx. 328/m ²
Fire test	AS/NZS 3837 class 2, BS 5852 Crib 5, BS 5852 part 1 with treatment, DIN 4102 B1, EN 1021-1/2, IMO FTP Code 2010 Part 8, NF D 60 013, NF P 92 503 M1, NFPA 701, SN 198 898 5.2, UNI 9177 Classe 1, US 1 Cal. Bull. 117-2013, ÖNORM B1/Q1
Lightfastness	5-7 (ISO 1-8)
Shrinking	App 2%
Abrasion Martindale	80.000 Martindale
Wash load	Half
Pilling	4-5 (ISO 1-5)
Colour	Slight differences may occur
Produced in environment	Greenguard Certification www.greenguard.org

Colors

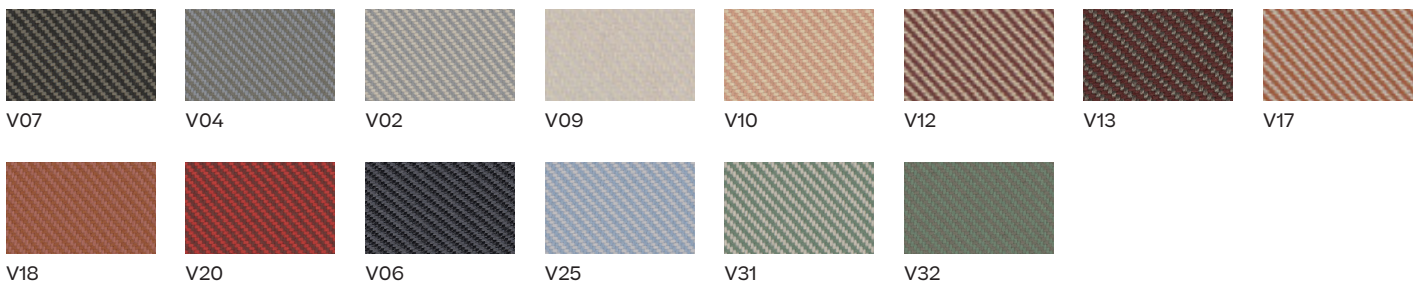

Recycled Cotton Wool

1. Ecological Product. Bio-sustainable. 80% recycled and 100% recyclable.
2. Safe in its installation: It does not cause discomfort or itching as it is based on natural fibers.
3. Elastic product. Does not break when folding. Its modulus of elasticity compared to rock wool is: 7 times better.

It does not promote combustion. Fire classification: M1 Certified 09/32300075 and 76 + according to UNE 23721-90, EN 13501-1.



Type 2
From cradle to gate with options



Local supplier

R

Recyclable



Nuvola

Nuvola is a soft material used exclusively on Pavilion O's side and roof panels. This material has excellent acoustic properties, and its soft texture, along with a wide range of colors, offers versatility, creating a welcoming space.

 Suitable for indoor use only

Technical specifications

Composition	100% Polyester made from recycled water/soda bottles without use of adhesives or other bonding agents
Thickness (mm)	12 (+/-1)
Weight (kg)	9mm: 1220 * 2240 mm sheet = 5.40 kg 12mm: 1220 * 2240 mm sheet = 6.60 kg
Density (kg/m3)	9mm: 200 12mm: 185
Fire testing	ASTM Class A
Environmental	Low-VOC, min 40% recycled PET 100 recyclable
Sound absorption	NRC 0.85 (20mm airgap) NRC 0.45 (direct surface mounting)

Colour Options

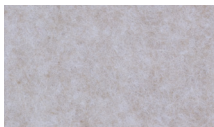

Andina Grey
PF1



Ibiza Sand
PF2

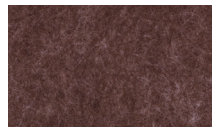

Hickory Brown
PF3



Baja Dunes
PF4



Iron Ore
PF5



Clary Sage
PF6

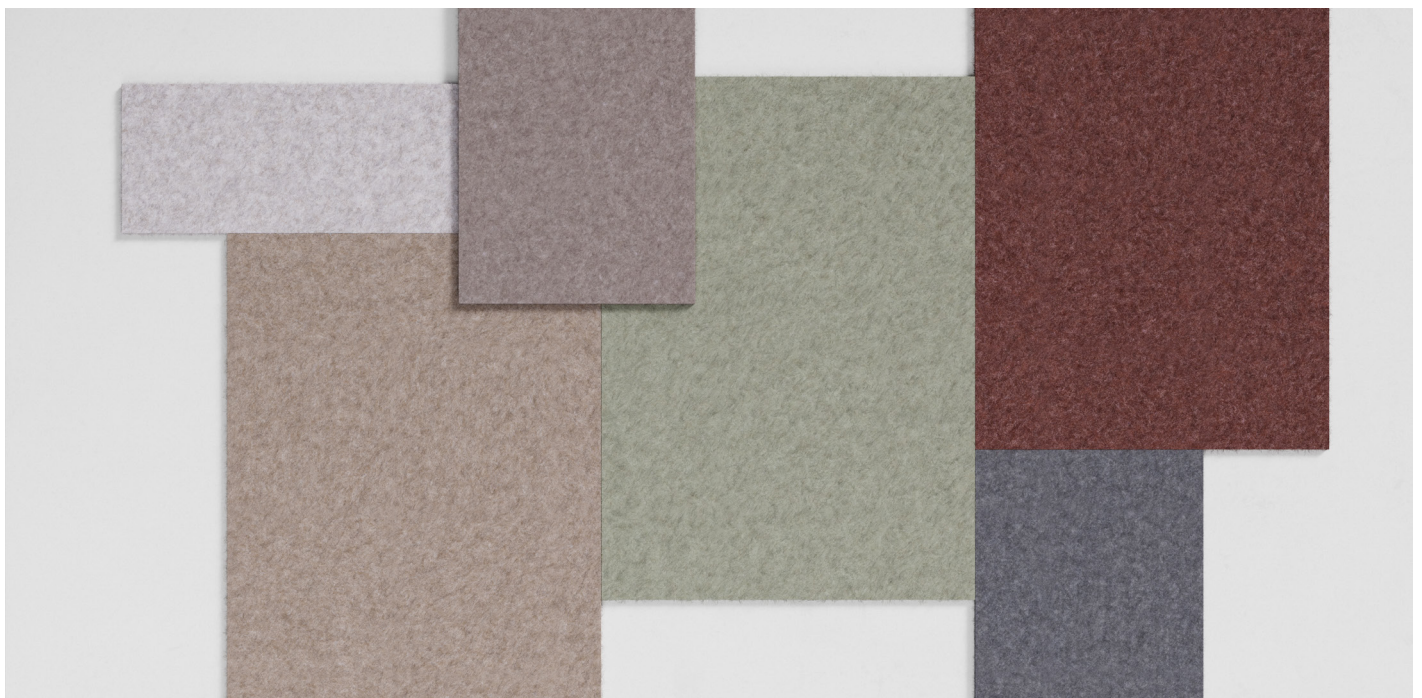

Soundproofing Membrane

High-density, polymer-based, asphalt-free synthetic soundproofing membrane.

Note

No substances including in the LIST OF PROHIBITED SUBSTANCES in CRADLE TO CRADLE CERTIFIED PRODUCTS PROGRAM are used in the manufacturing of the product range Soundproofing Membrane so those substances are not expected to be on the final product.

Restricted Substances (REACH Annex 17)"

The item(s) stated within section "2" of this declaration satisfy the requirements that are defined in Title VIII of Regulation (EC) No. 1907/2006 (REACH regulation), including the restrictions listed in Annex 17 of REACH.

Link: <https://echa.europa.eu/substances-restricted-under-reach>



Local supplier

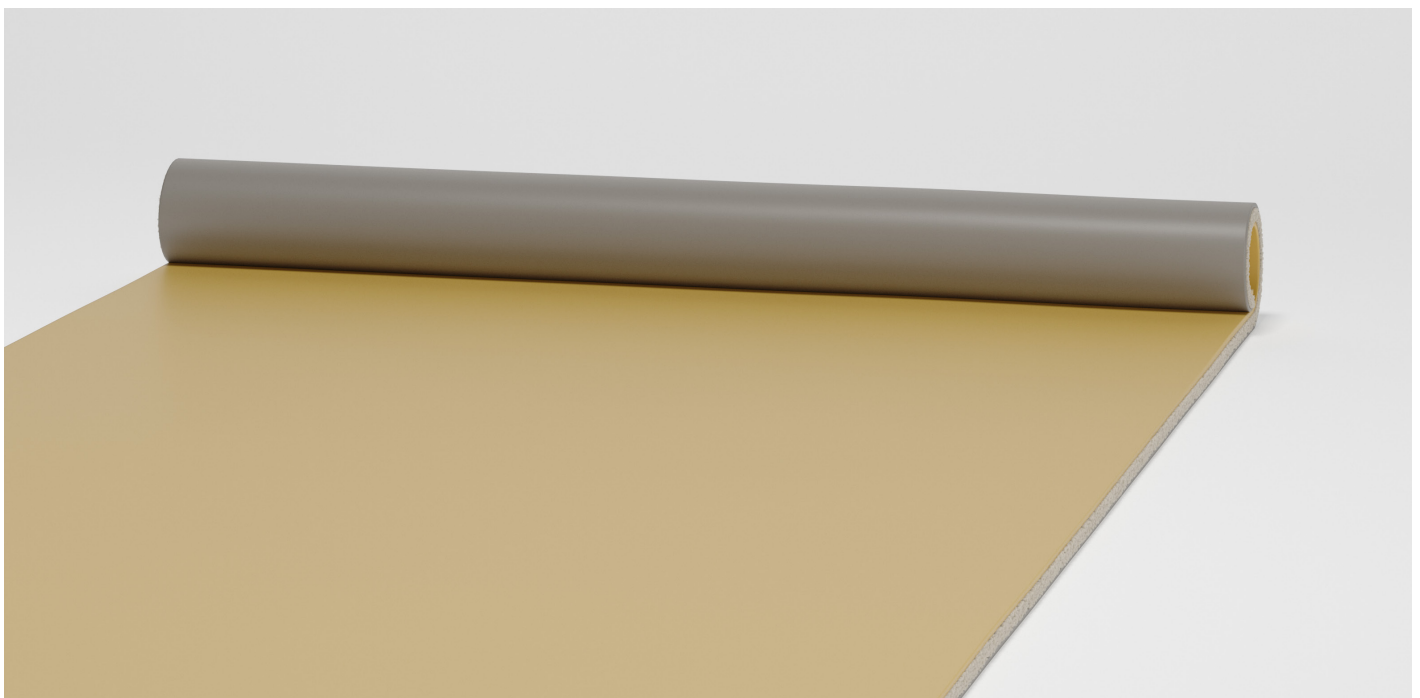

Soundproofing Membrane

Characteristics	Testing method	Tecsoundsy	Units
Density	-	2.010	kg/m ³
Tensile strength	NT-67	>30	N/50mm
Elongation	NT-67	>500	%
Fold	EN 1109	-20	°C
Fire classification	UNE-EN 13501-1	Bs2d0	-
Resistance factor to water steam	UNE-EN 1931 met B	μ>1806	-
Water absorption (24h at 23°C)	1S062 met 1 NT74	0,003	%
Shore A hardness	NT74	30±10	

Regulation or protocol	Conclusion	Version of regulation of protocol
French VOC Regulation		Regulation of March and April 2011 (DEVL1101903D and DEVL1104875A)
French CMR components	Pass	Regulation of March and April 2011 (DEVL1101903D and DEVL1104875A)
AgBB/ABG	Pass	Anforderungen an bauliche Anlagen bezüglich des Gesundheitsschutzes (ABG), Entwurf 31.08.2017
Belgian Regulation	Pass	Royal decree of May 2015 (C-2014/24239)
Indoor Air Comfort®	Pass	Indoor Air Comfort 6.0 of February 2017
Indoor Air Comfort GOLD®	Pass	Indoor Air Comfort GOLD 6.0 of February 2017
Blue Angel (RAL UZ 132)	Fail	Low-Emission Thermal Insulation Material and Suspended Ceilings for Use in Buildings, October 2010
BREEAM International	Compliant	GN22 v2.2 (August 2017): BREEAM Recognised Schemes for VOC Emissions from Building Products
LEED v4 (outside U.S.)	Compliant	LEED v4 for Building Design and Construction (April 2015)

Phone booth
Technical data

kettal

Power

Voltage Input: 100-240VAC (single-phase)
Frequency Input: 50-60Hz
Available system power: 16A (The electrical system is designed to support up to the right power)
NETWORK line – RJ45 POE+
Outlets support up to a total of 10A.

Power connection

Connection through one side of a column



Illustration 2 - Power and data connection through column side

When:

If the client does not have a raised floor and needs a surface-laid connection to the pavilion, the client must select this type of connection for the room.

How:

The column selected as “power supply and data input” will have a (male) surface connector.

The client must provide a power line up to that point.

To make the connection, Kettal provides a connector with a selected country plug to plug directly into the office socket.

Required cable

AWG 14
3 x 2,5 mm² Cu
450/750B
H05ZZ

Sensor - STD format

Operation through presence sensor:
When the user enters, the lighting and ventilation are turned on. When the user leaves, after 15 minutes, both the lighting and the ventilation are turned off.

The Pavilion system allows 4 project layers depending on what the client prefers:

A. Standard

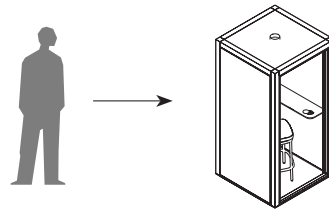

Phone Booth STD (with Sensor or Sensor + Dimmer). It is not connected to any control / management system.

How to determine the number of Hubs per project

The number of Hubs per project should be studied based on the layout of the rooms and the project based on the following product specifications.

It is necessary to connect to the customer's network through the RJ45 connection provided by the Hub.

All wireless devices to be associated with the wireless hub must be within 22 m (71 ft) of the wireless hub and must be on the same floor as the hub.

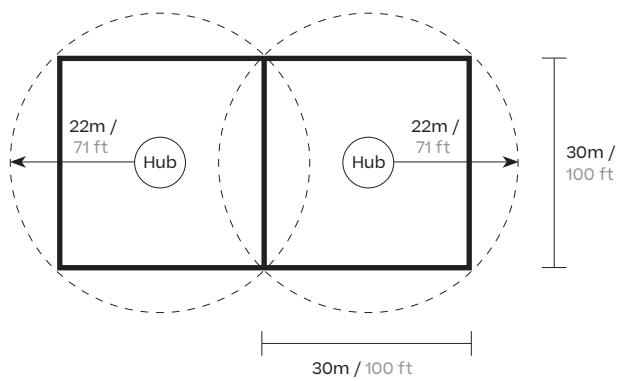

B. Hub — Control

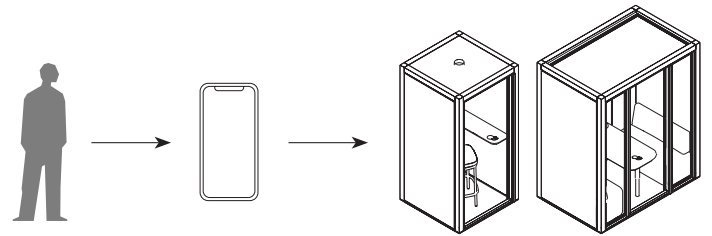

Allows the connection of each Phone Booth and Pavilion O to a Management Software for the client.

This is achieved through a HUB (which is installed in the customer's building), which must be connected to the network and which interconnects all rooms and Phone Booths.

Bacnet Integration

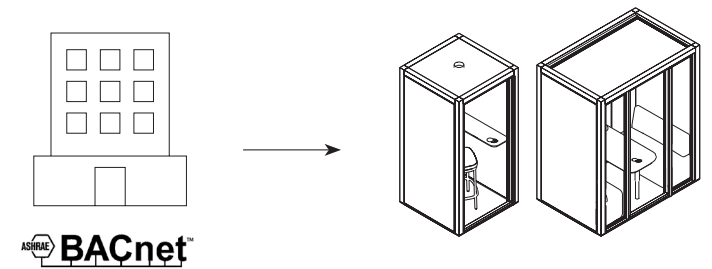

Allows the connection of each Phone Booth and Pavilion O to the building's BMS (Building Management System) system through the Bacnet IP protocol.

This is achieved through a Bacnet licensed Hub (which is installed in the customer's building), which must be connected to the network and which interconnects all rooms and Phone Booths.

System's basic information

Operation through presence sensor:
When the user enters, the lighting and ventilation are turned on. When the user leaves, after 15 minutes, both the lighting and the ventilation are turned off.

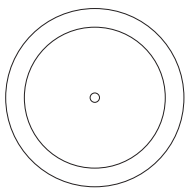

Wireless hub



- Response to demand
- Bacnet integration
- API integration

Wireless controls and flexible sensors

- Remote controls
- Presence and daylight sensors
- Lighting controllers
- Home appliance charge controllers
- Integrated luminaire sensors and control

Easy to use Software

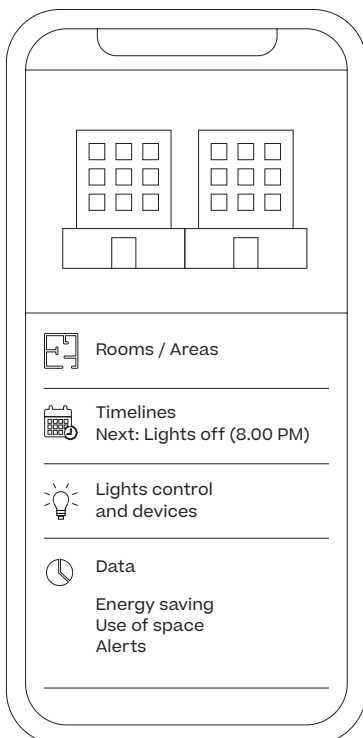

Communication protocols



Communicate by RF with control components



Communicate over WiFi with smart devices



Communicate via Ethernet cable to the hub

Security system

Technical data

Designer
Kettal Studio

Collection
Phone Booth

Safety by design

1. Isolated wired or wireless architecture that strictly limits the ability of the hub's Wi-Fi to be used to access the corporate network to obtain confidential information.
2. Distributed security architecture: each hub has its own keys.
3. NIST-recommended best practices for password security, including tampering with and using Scrypt.
4. AES 128 bit encryption for network communications.
5. HTTPS protocol (TLS 1.2) to secure connections to the hub in the wired network.
6. WPA2 technology to ensure connections to the hub in the Wi-Fi network.

Third party validation

1. Various external experts involved during the design process.
2. Penetration tests carried out by third parties to identify and correct potential vulnerabilities before installation.

Monitoring and continuous improvements

A dedicated security team is used to constantly monitor potential threats and, when required, submit security patches to update installed systems.

Permanent support

1. IT implementation guidelines
2. Guidance from our world-class 24/7 technical support organization with IT expertise, throughout the product lifecycle